

CP-2014 CONVERBABY

ES • IMPORTANTE: A CONSERVAR PARA FUTURAS CONSULTAS. LÉASE ATENTAMENTE.

EN • IMPORTANT: PLEASE KEEP FOR FUTURE REFERENCE. READ CAREFULLY.

FR • ATTENTION: CONSERVER POUR CONSULTER AU FUTUR.

IT • IMPORTANTE: LEGGERE ATTENTAMENTE LE ISTRUZIONE. TENERE PER FUTURE CONSULTAZIONE.

PT • IMPORTANTE: MANTENHA PARA FUTURAS CONSULTAS. LÉASE ATENTAMENTE.

R • ВАЖНО: СОХРАНИТЕ ДЛЯ ДАЛЬНЕЙШЕГО ИСПОЛЬЗОВАНИЯ. ВНИМАТЕЛЬНО ПРОЧТИТЕ.

A • لامعتسالا لابق اديج أرقا .ةعجارمئل ظفح ا.م.

CN • 重要事项：保留以备将来参考，请仔细阅读。



MINICUNA BIG
BIG MINI CRIB



PAG 3-8

COLECHO
CO-SLEEPING



PAG 9-12

PARQUE DE JUEGOS
PLAYGROUND

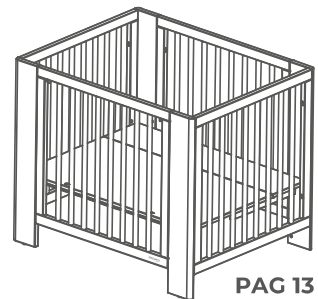

PAG 13

CUNA
CRIB



PAG 14-17

SOFÁ JUNIOR
JUNIOR SOFA

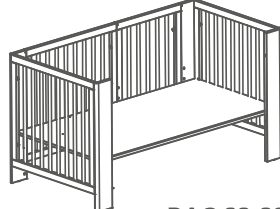

PAG 22-29

CAMA JUNIOR
JUNIOR BED

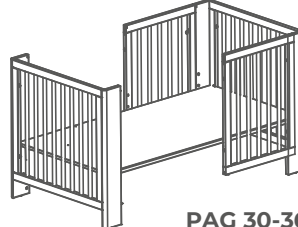

PAG 30-36

ESCRITORIO
DESK

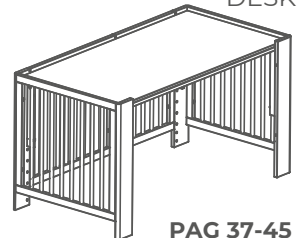

PAG 37-45

SOFÁ MONTESSORI
MONTESSORI SOFA

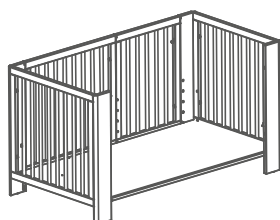

PAG 22-29

CAMA MONTESSORI
MONTESSORI BED

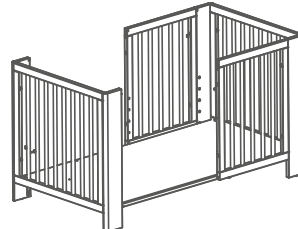

PAG 30-36



ESPESOR MÁXIMO DE COLCHÓN
MAXIMUM MATTRESS THICKNESS



40'



NOT INCLUDED



ALLEN 4MM



ALLEN 5MM

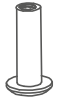

C09524
X4(M6X30)



C07915
X6(M6X15)



C08300
X12(M6X30)

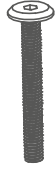

C06545
X4(M6X50)

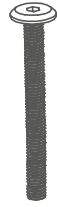

C05556
X2(M6X60) X2



C15247
X2



C07376
X4



C10313
X4



C14647
X2



C15246
X2



N X1

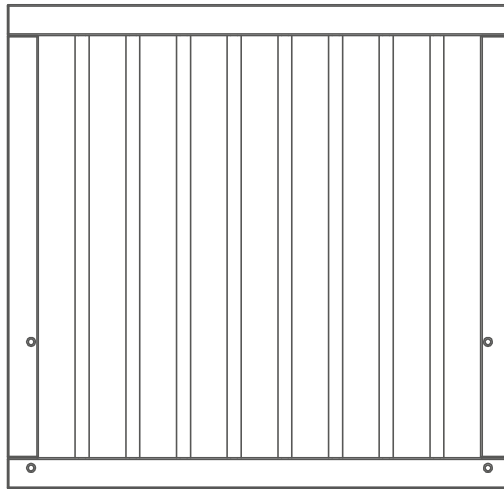

O X2



P X2

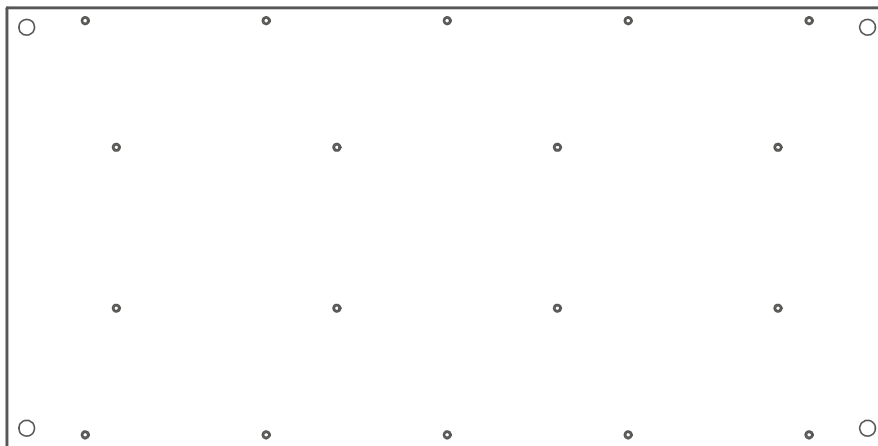

Q X1

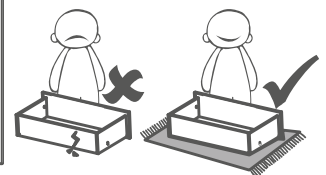

1 ALLEN 4MM

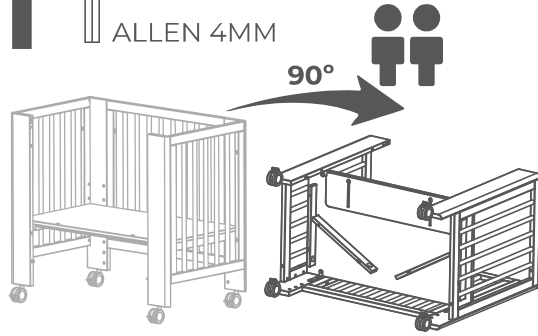

MINICUNA BIG
BIG MINI CRIB

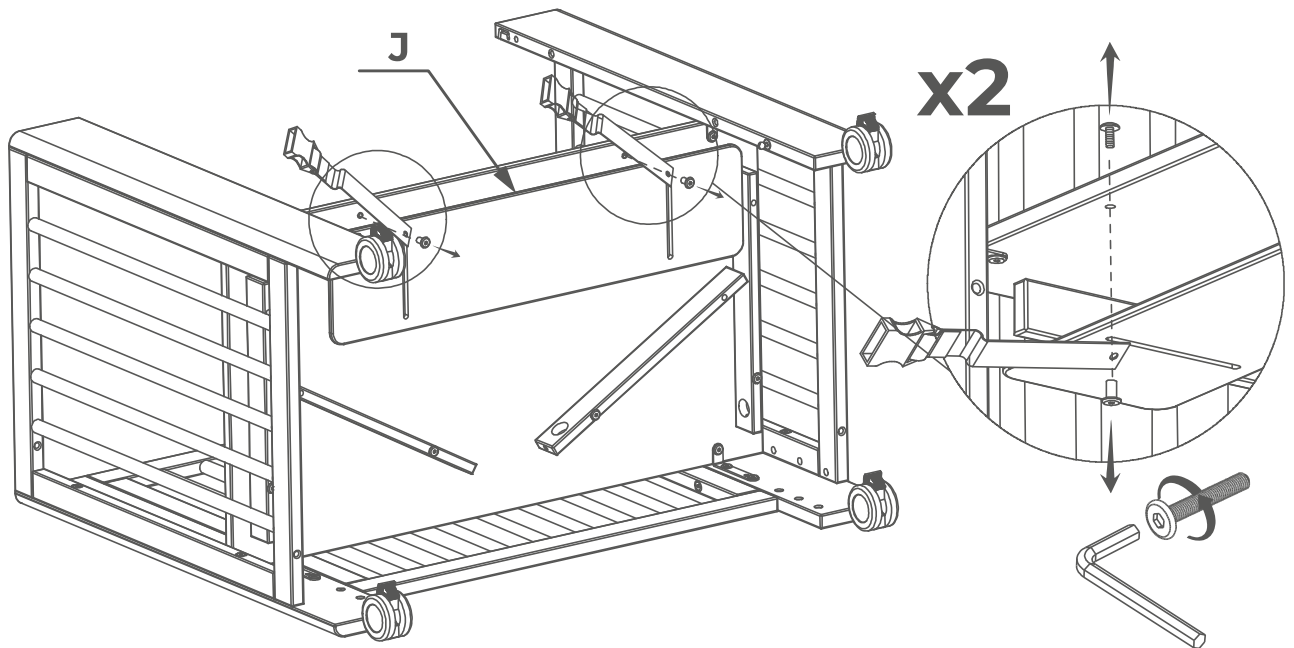

2 ALLEN 4MM

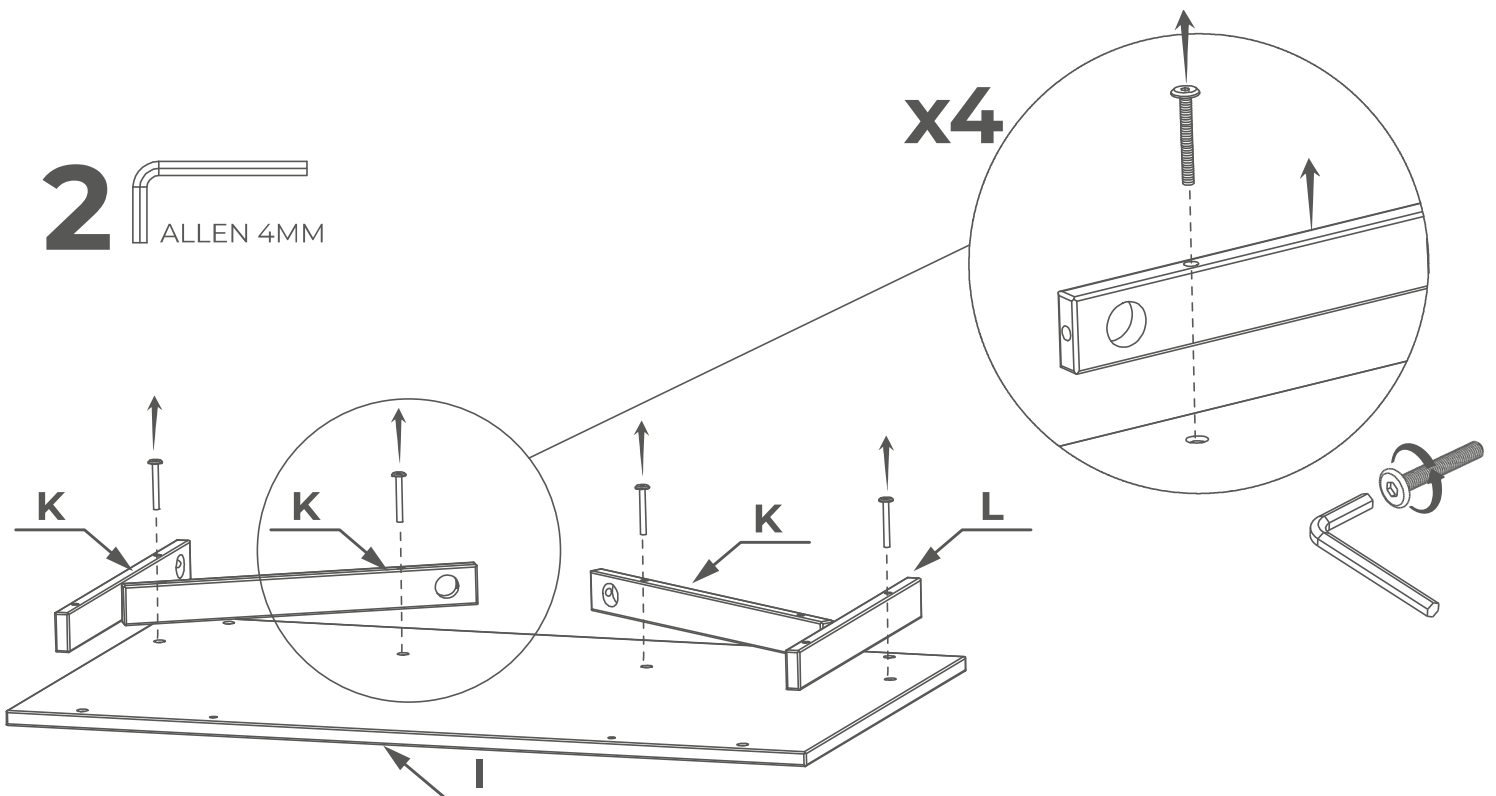

3 ALLEN 4MM

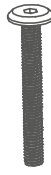

C06545
X8(M6X50)



C07915
X2(M6X15)

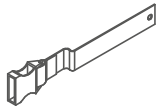

5024997-A
X2



C09502
X2(M6X15)

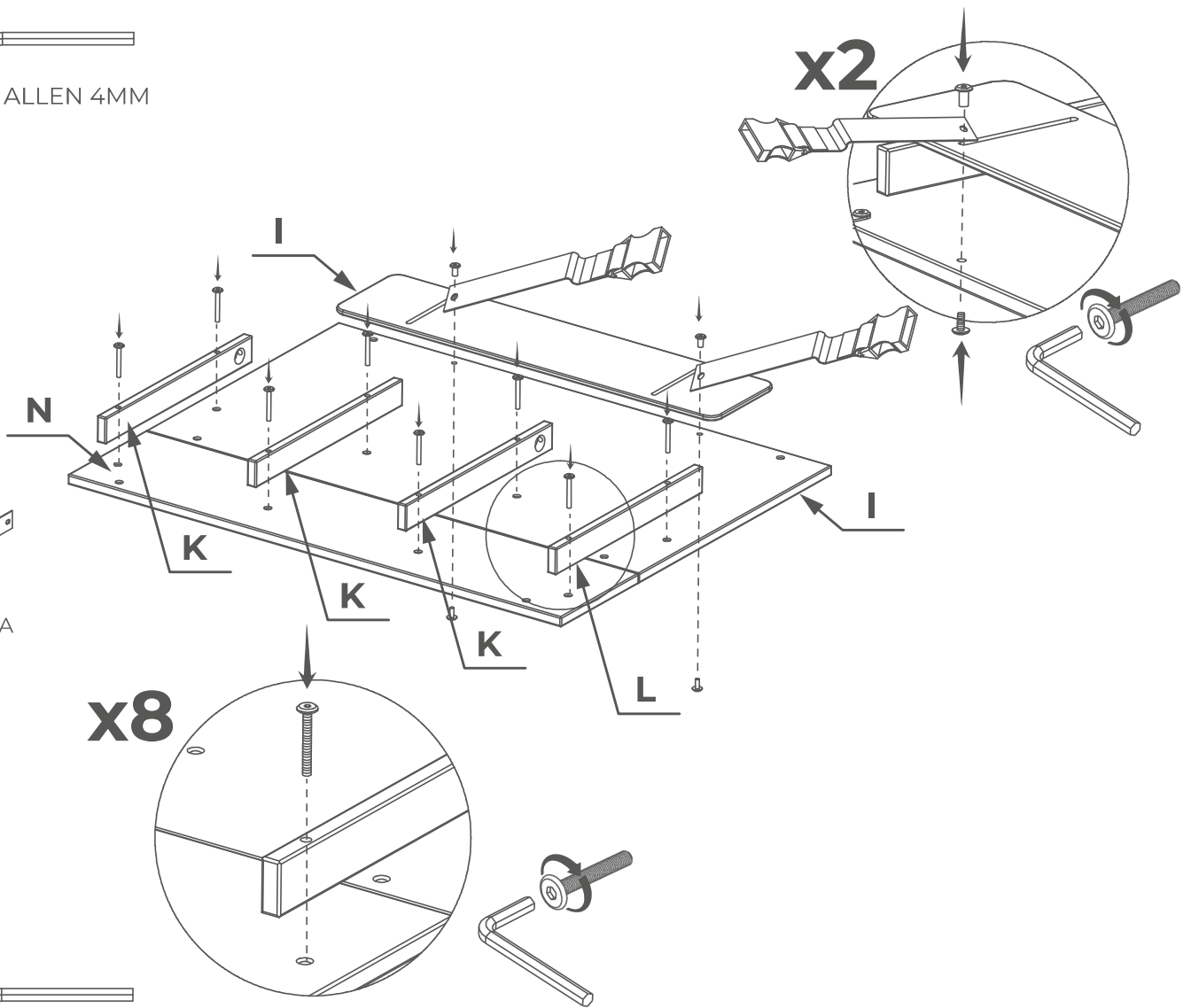

4 ALLEN 4MM

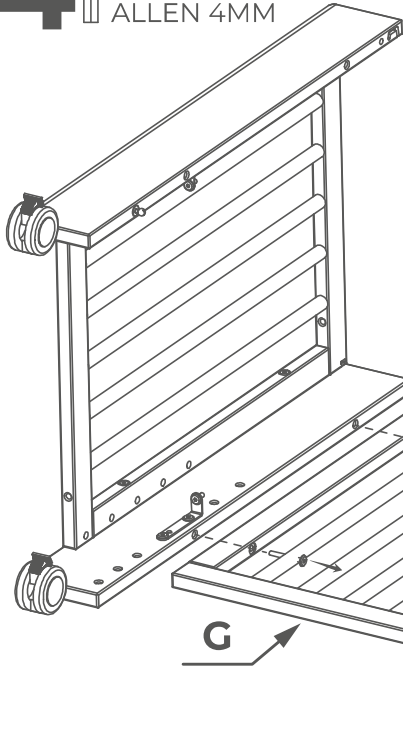

5 ALLEN 4MM

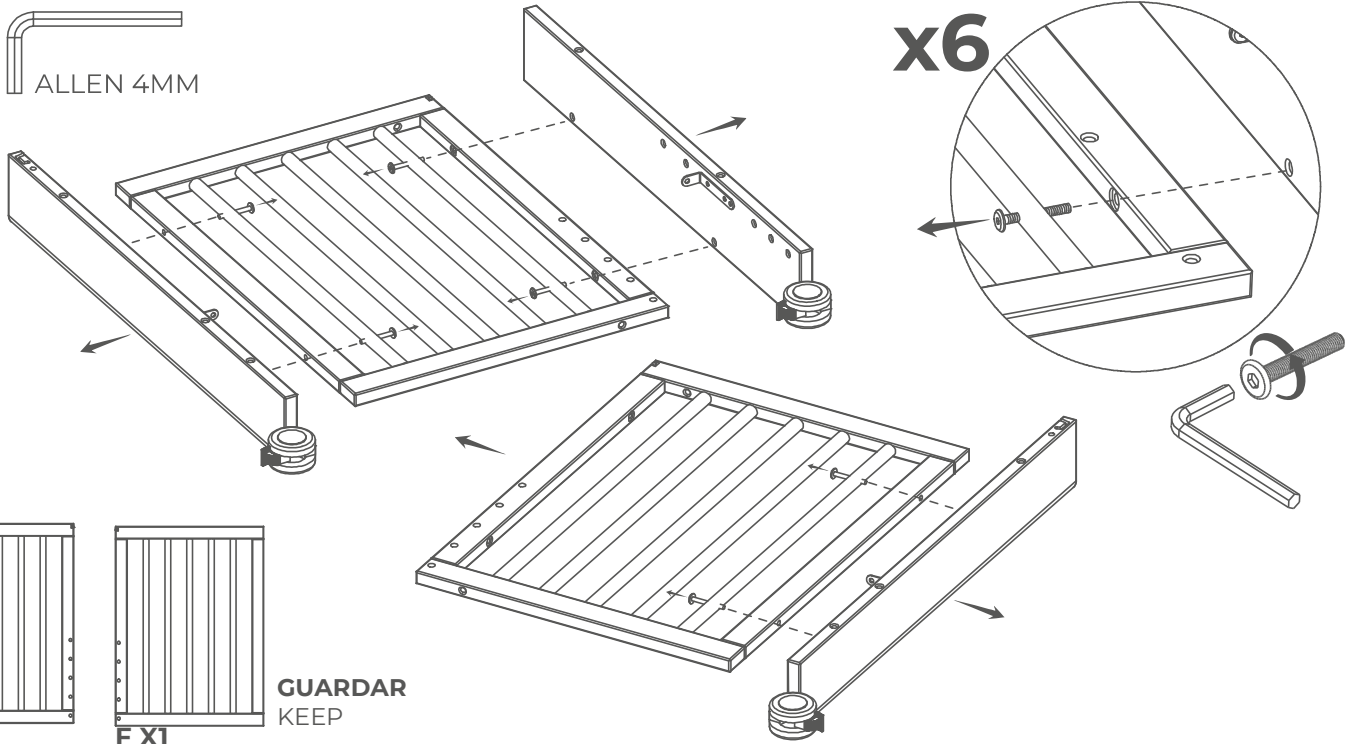

x6

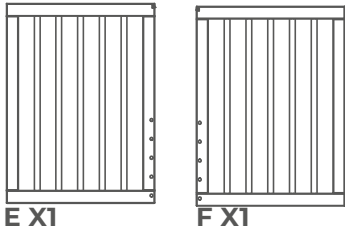

**GUARDAR
KEEP**

6 ALLEN 4MM

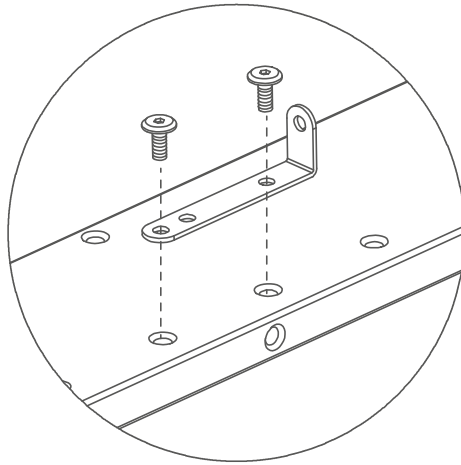

MEDIDAS CON RUEDAS INCLUIDAS
Desde parte superior del somier al suelo
MEASUREMENTS WITH WHEELS INCLUDED
From the top of the bed base to the floor



A,B,C,D

- 7°+6=504mm
- 6°+5=440mm
- 5°+4=376mm
- 4°+3=312mm
- 3°+2=248mm
- 2°+1=200mm

7 ALLEN 4MM

x6

**C06545
X6 (M6X50)**

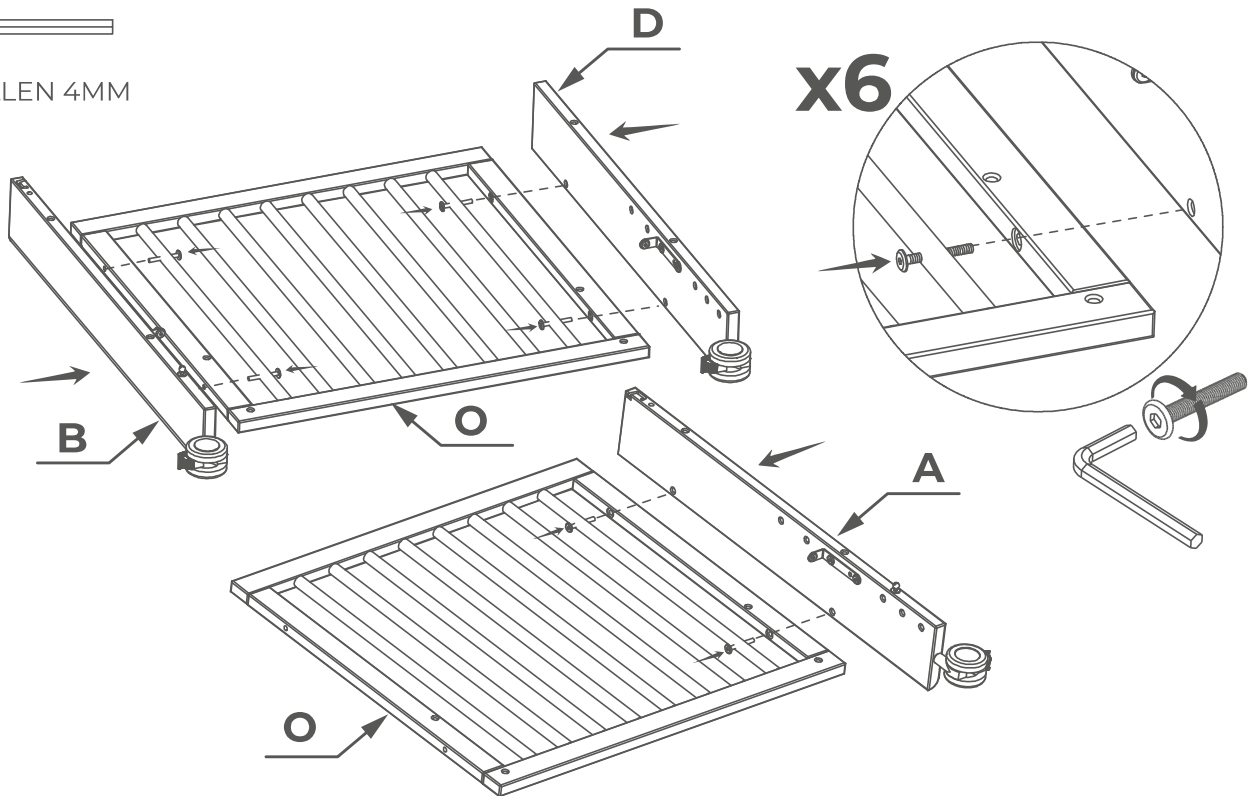

8

ALLEN 4MM

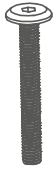

C06545
X4 (M6X50)

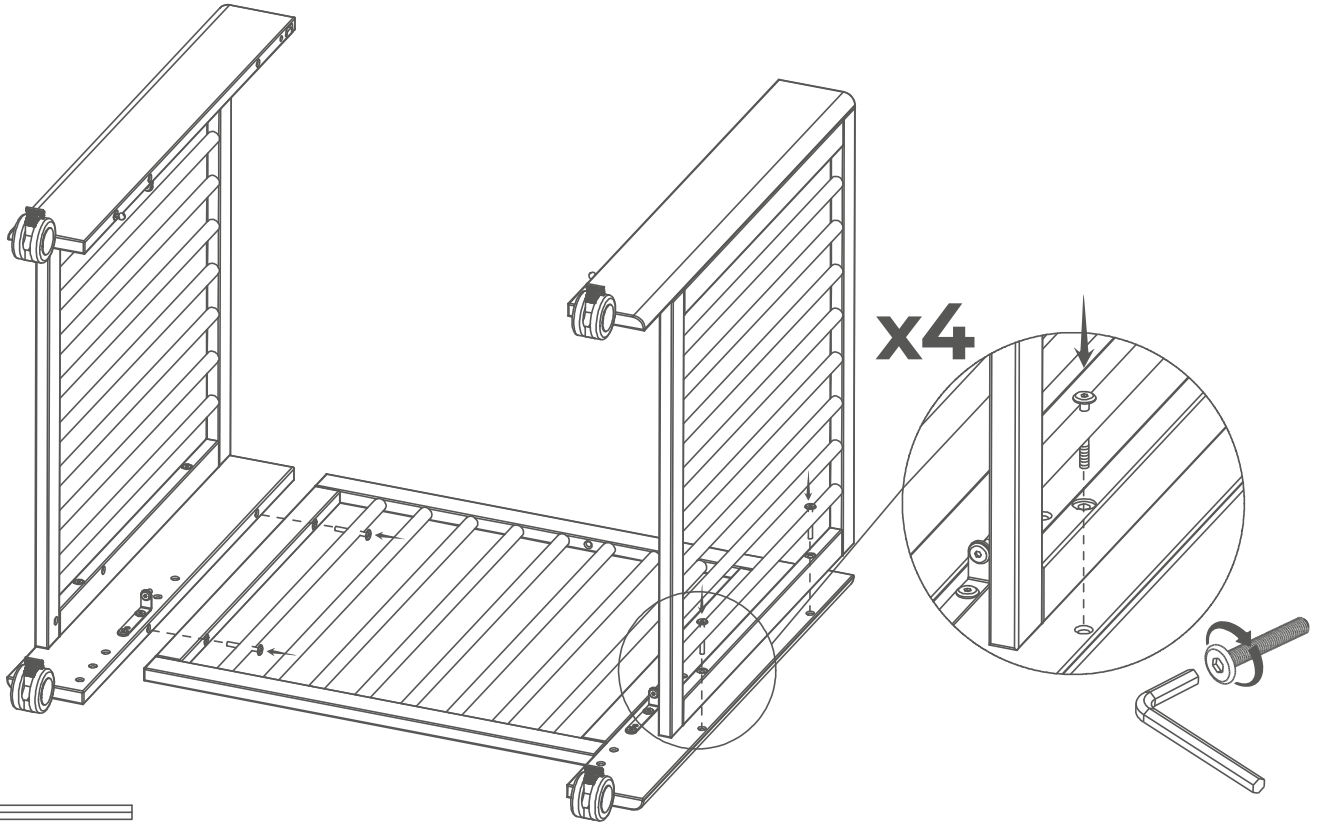

9

ALLEN 4MM



C07915
X4 (M6X15)

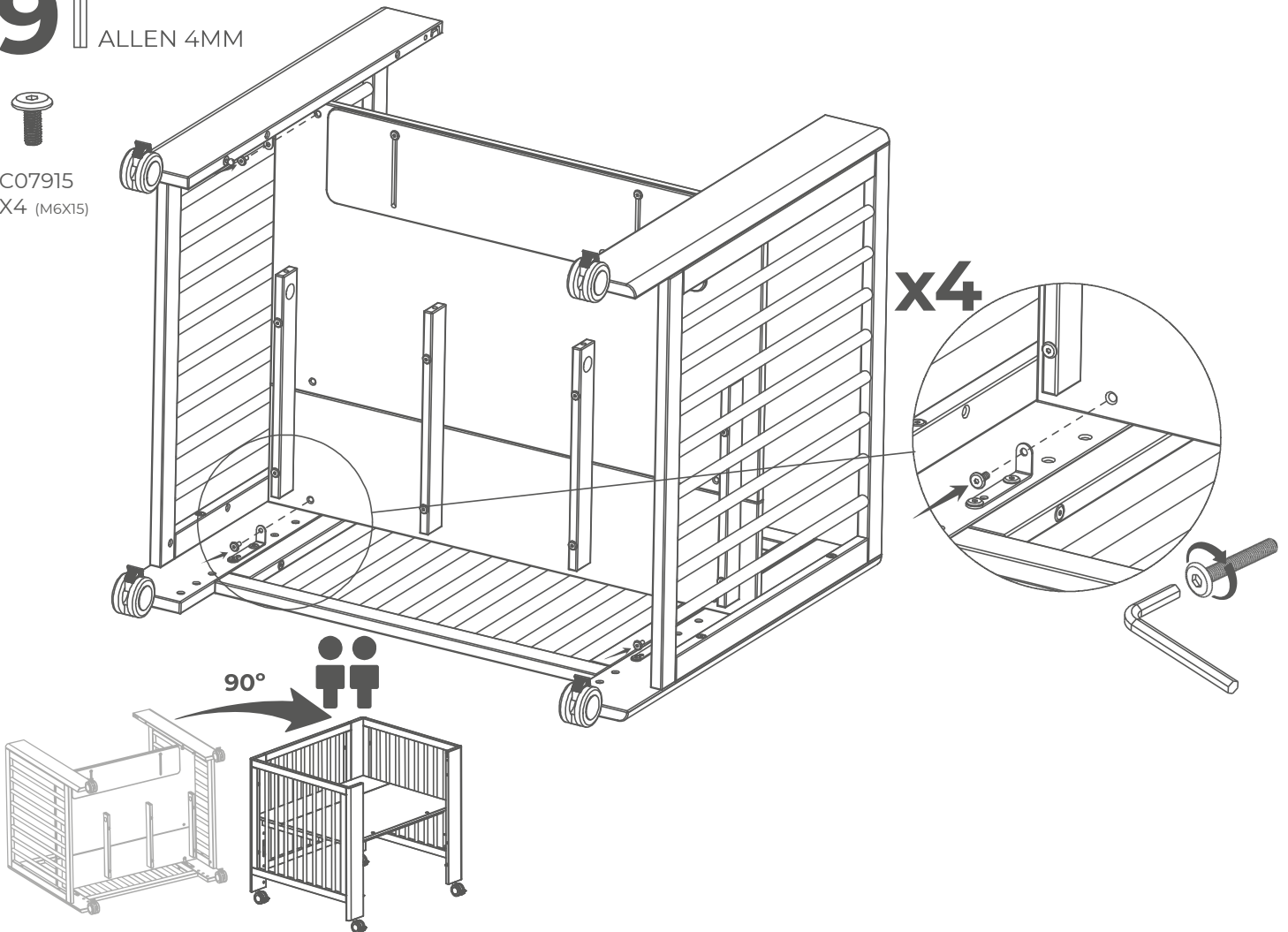

COLOCACIÓN LATERAL MÓVIL
MOBILE SIDE PLACEMENT

micuna CARA DELANTERA
made with love FRONT FACE

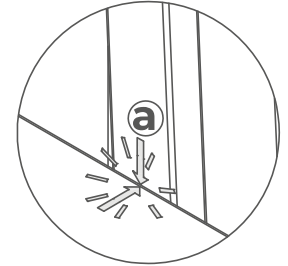
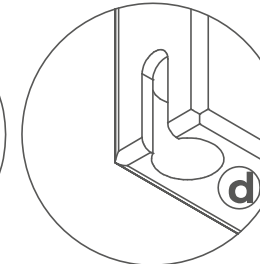
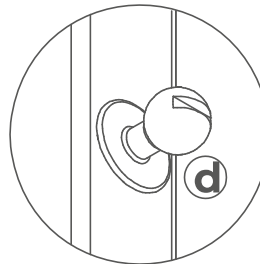
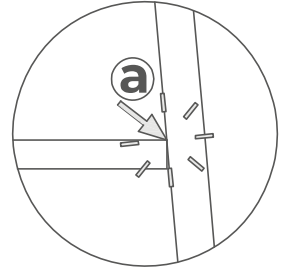
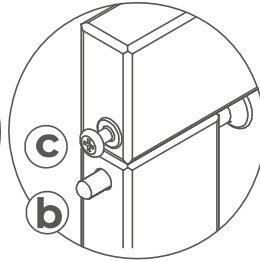
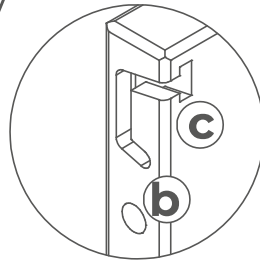
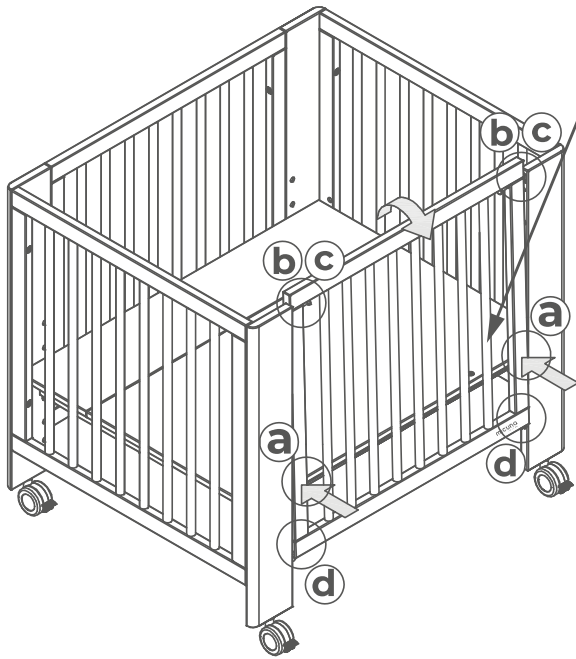

10 

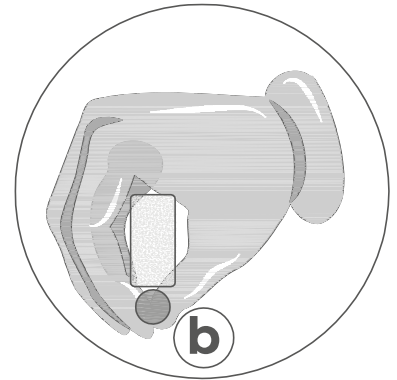
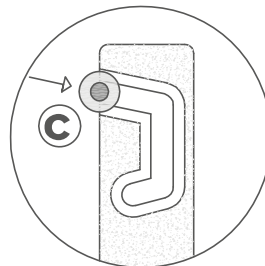
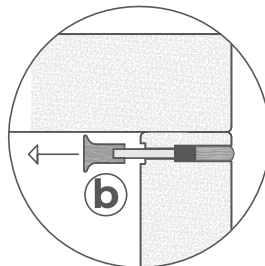
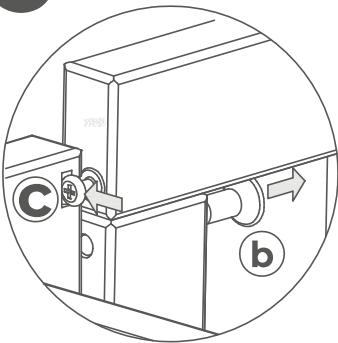

11 

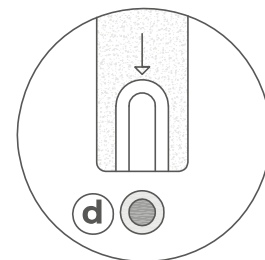
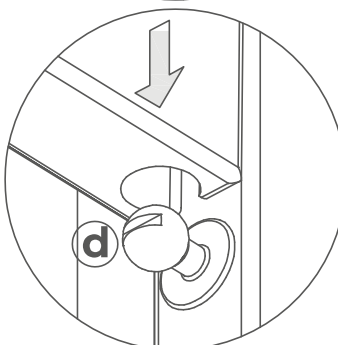
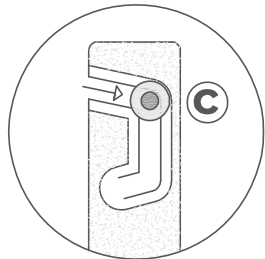
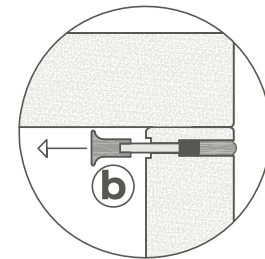
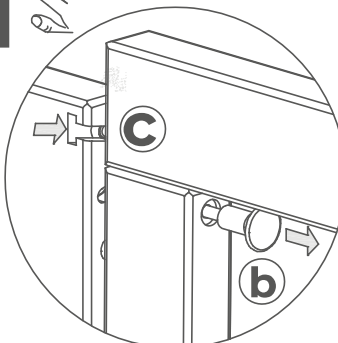

12

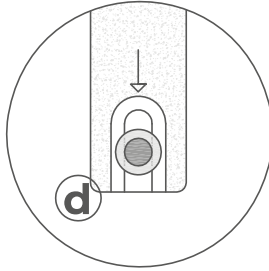
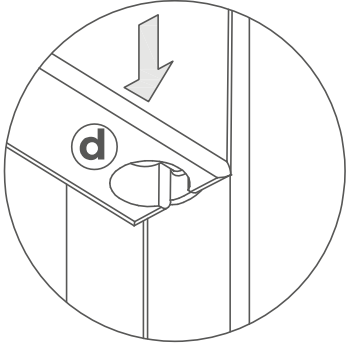
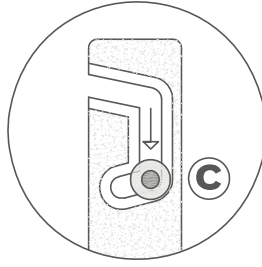
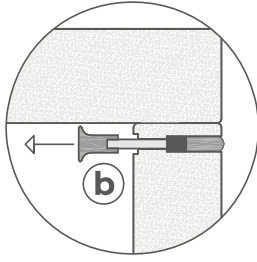
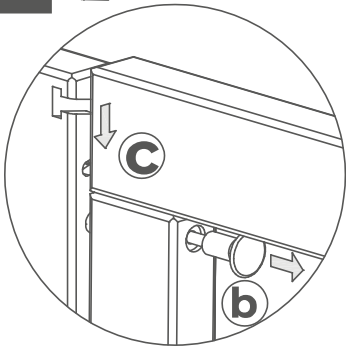

13

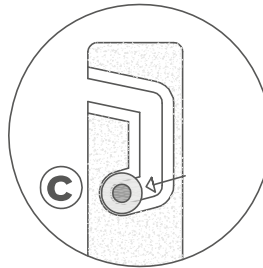
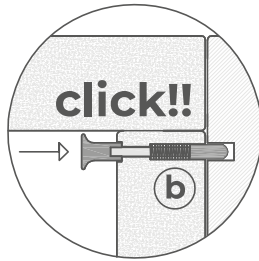
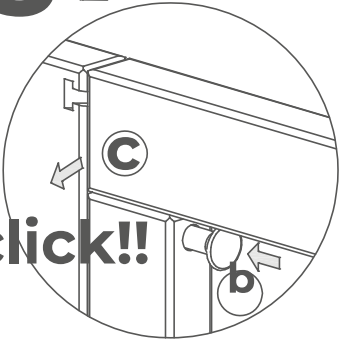

OK!!!

EXTRACCIÓN LATERAL MÓVIL
MOBILE SIDE EXTRACTION

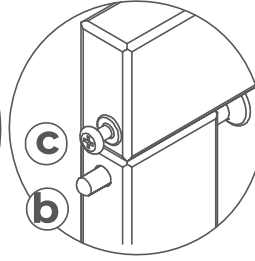
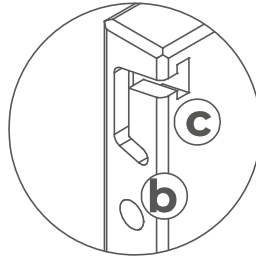
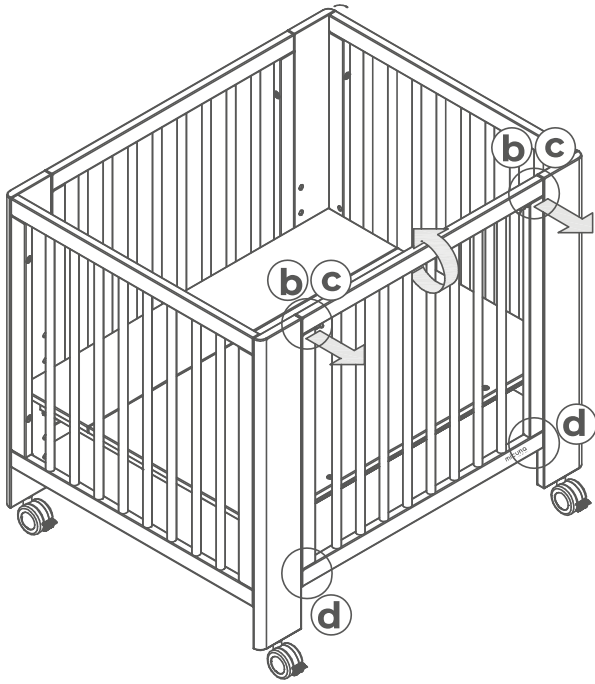

COLECHO
CO-SLEEPING

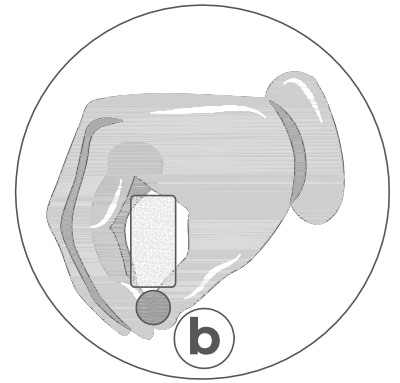
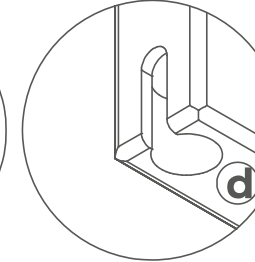
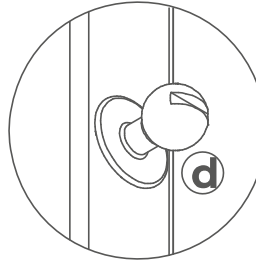

1

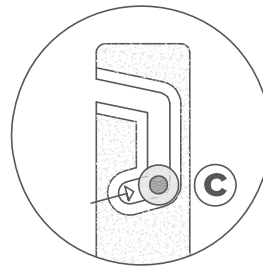
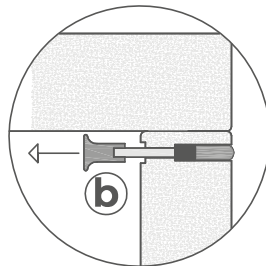
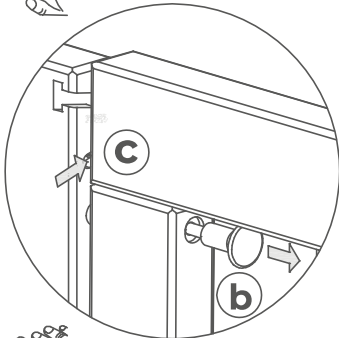

2

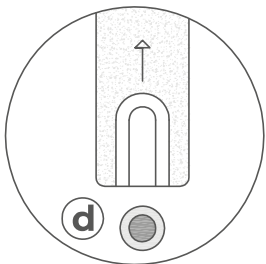
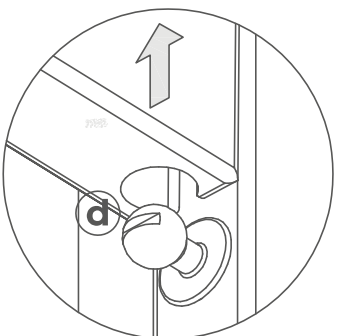
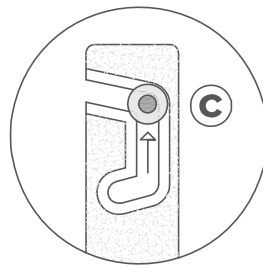
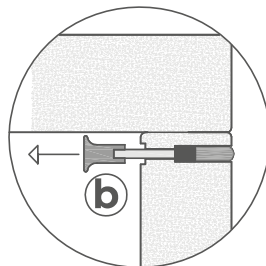
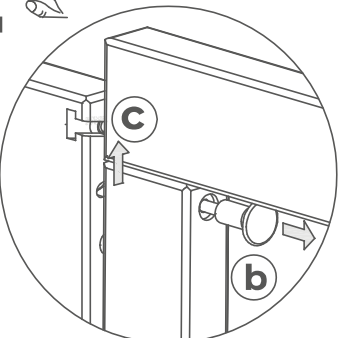

3

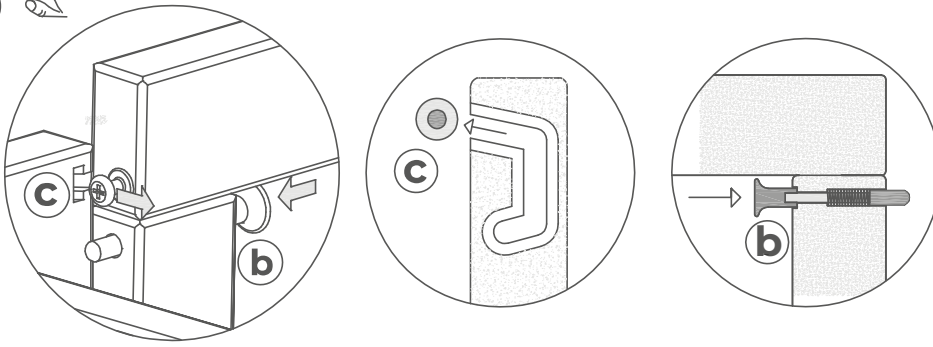

4



$X \leq Y$

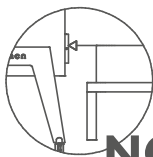

NOK

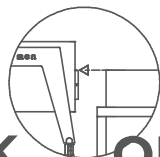

OK

ADVERTENCIA: El colchón de la cama de adulto debe estar al mismo nivel o más alto que el somier de la cuna.

WARNING: The mattress of the adult bed should be at the same level or higher than the bed base of the crib.

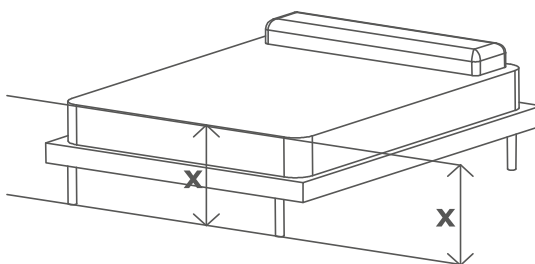
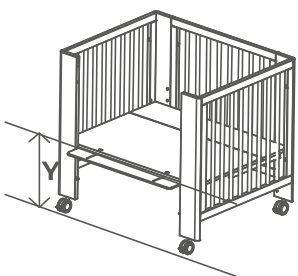

A,B,C,D

MEDIDAS CON RUEDAS INCLUIDAS
Desde parte superior del somier al suelo
MEASUREMENTS WITH WHEELS INCLUDED
From the top of the bed base to the floor

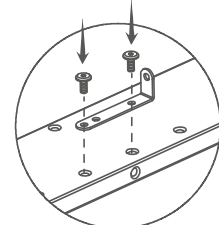

- 7+6=504mm
- 6+5=440mm
- 5+4=376mm
- 4+3=312mm
- 3+2=248mm
- 2+1=200mm

5

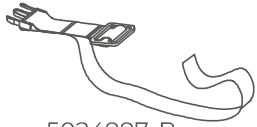

5024997-B
X2

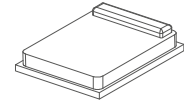

5a

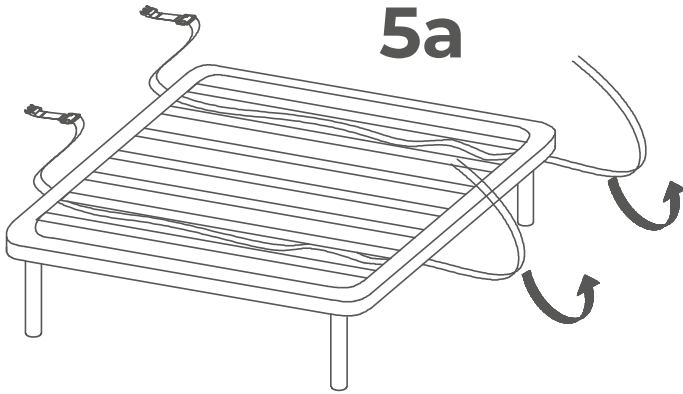

5a

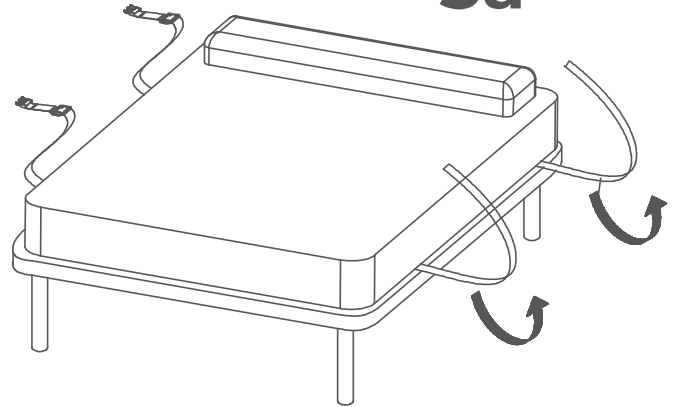

5b

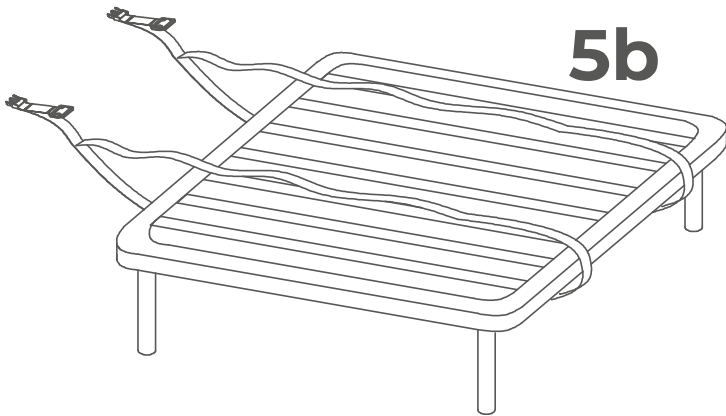

5b

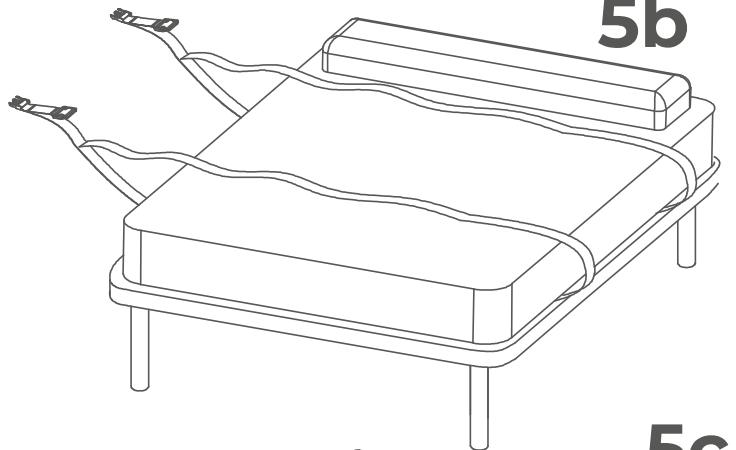

5c

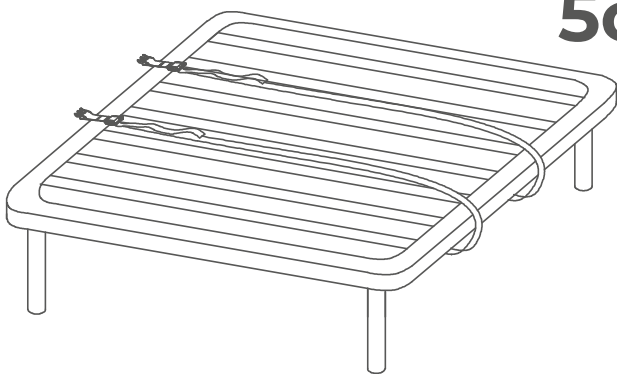

5c

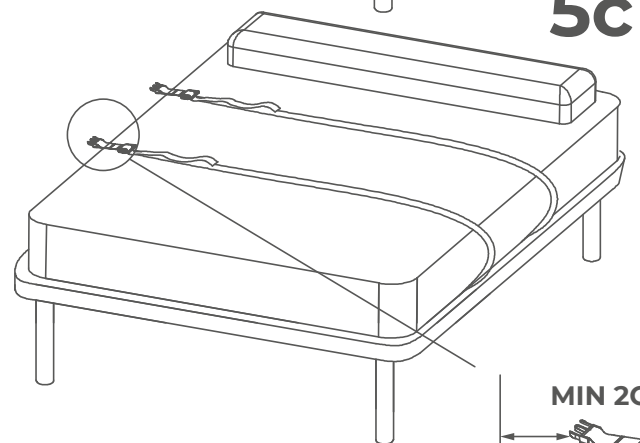

MIN 2CM

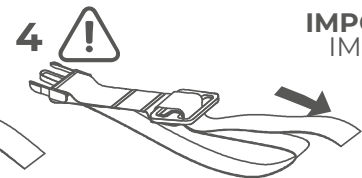
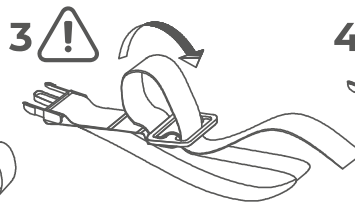
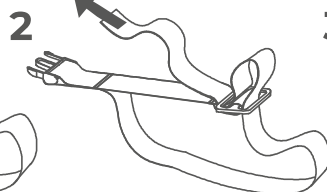
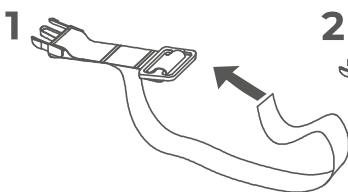
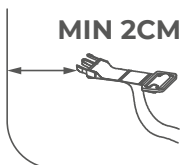

IMPORTANTE
IMPORTANT



6

ADVERTENCIA: Asegúre que no queda hueco entre la cuna colecho y la cama del adulto.
WARNING: Make sure there is no gap between the co-sleeping crib and the adult's bed.

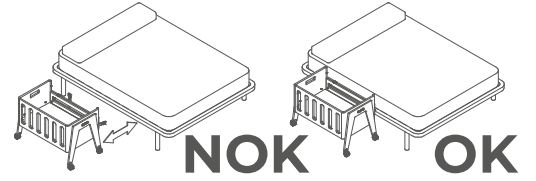
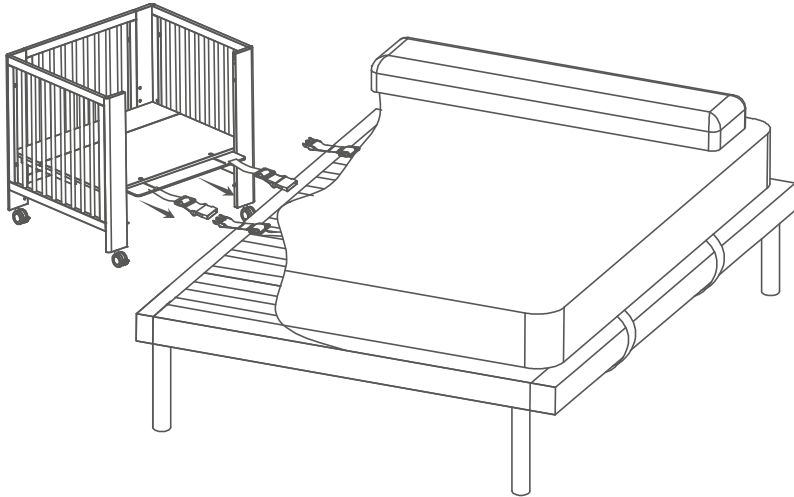

click!!

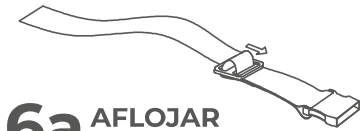

6a AFLOJAR
LOOSEN UP



6b ENGANCHAR
TO HOOK

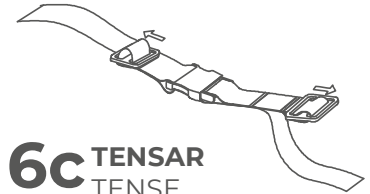

6c TENSAR
TENSE

7

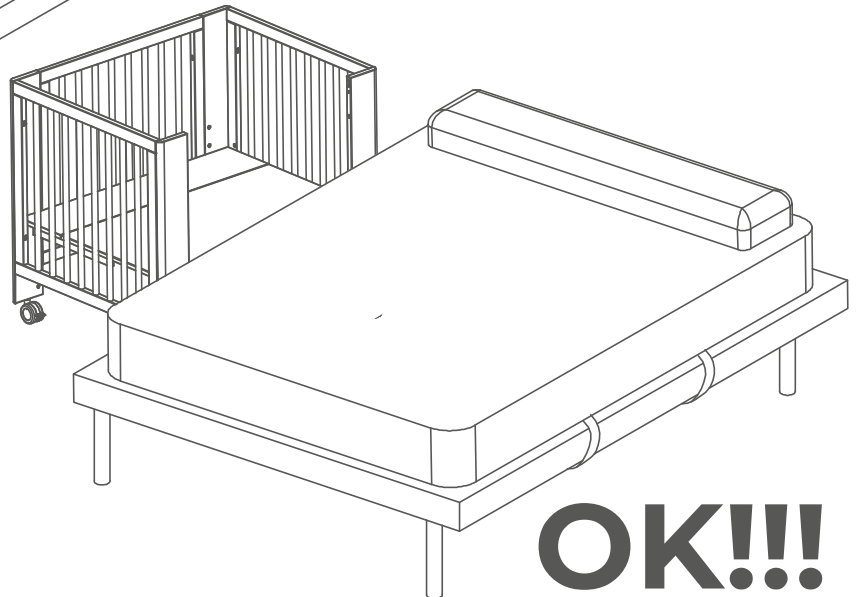
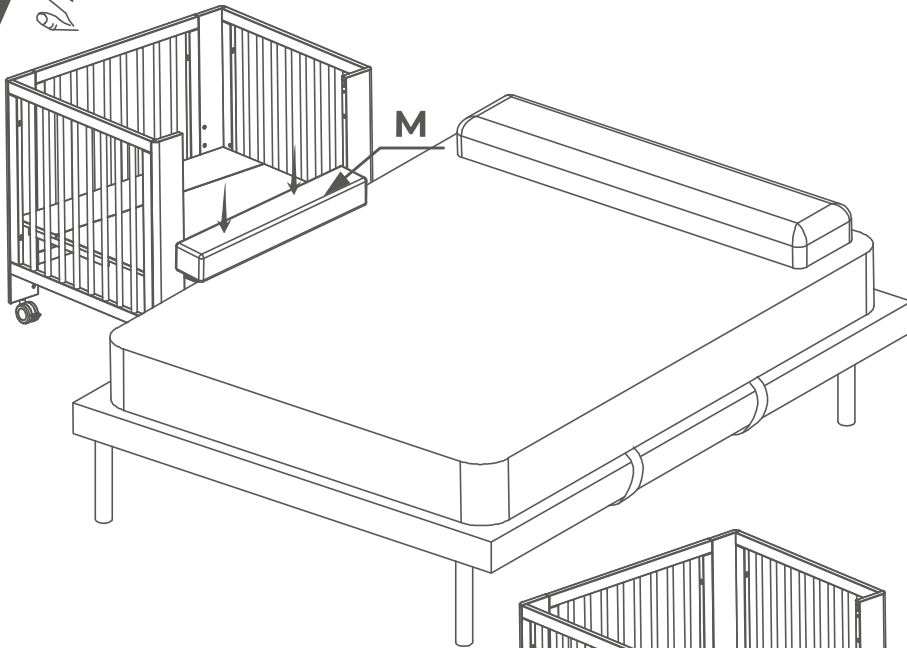

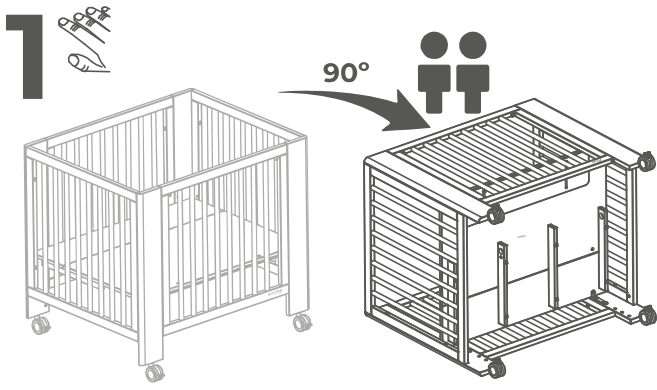

PARQUE DE JUEGOS
PLAYGROUND

A,B,C,D

MEDIDAS SIN RUEDAS
Desde parte superior del somier al suelo
MEASUREMENTS WITHOUT WHEELS
From the top of the bed base to the floor

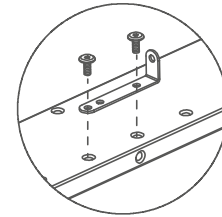
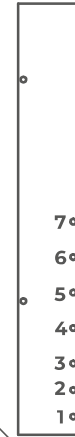

- 7+6=424mm
- 6+5=360mm
- 5+4=296mm
- 4+3=232mm
- 3+2=168mm
- 2+1=120mm

x4

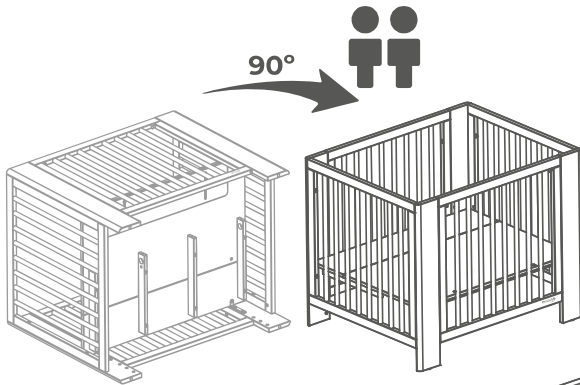
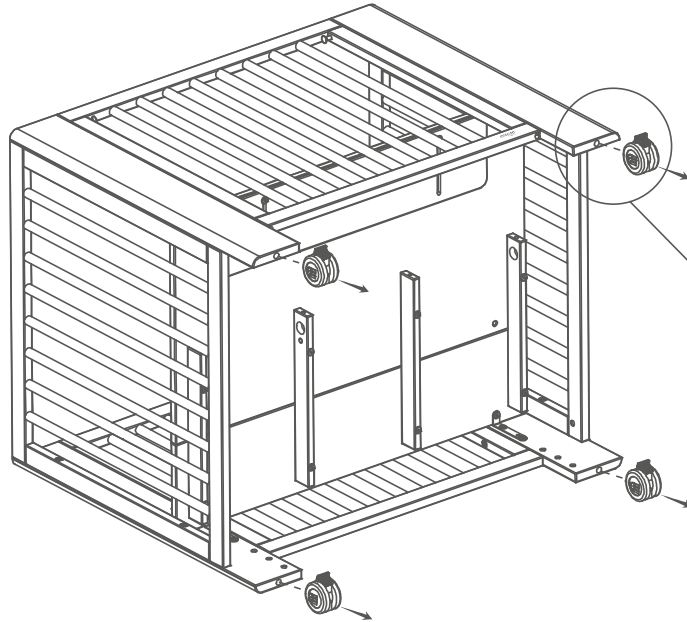
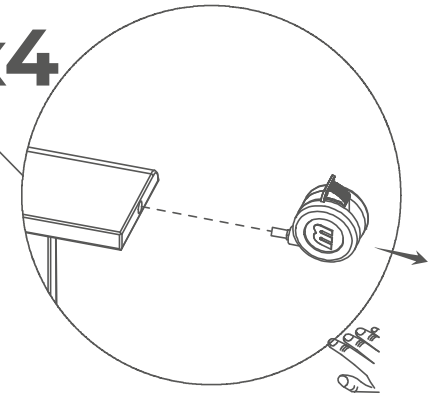

OK!!!

1 ALLEN 4MM

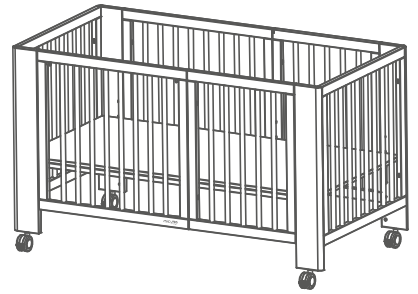
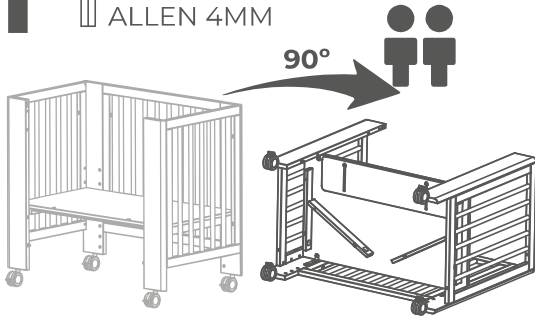

*No guarda mano. Does not keep hand.

CUNA
CRIB

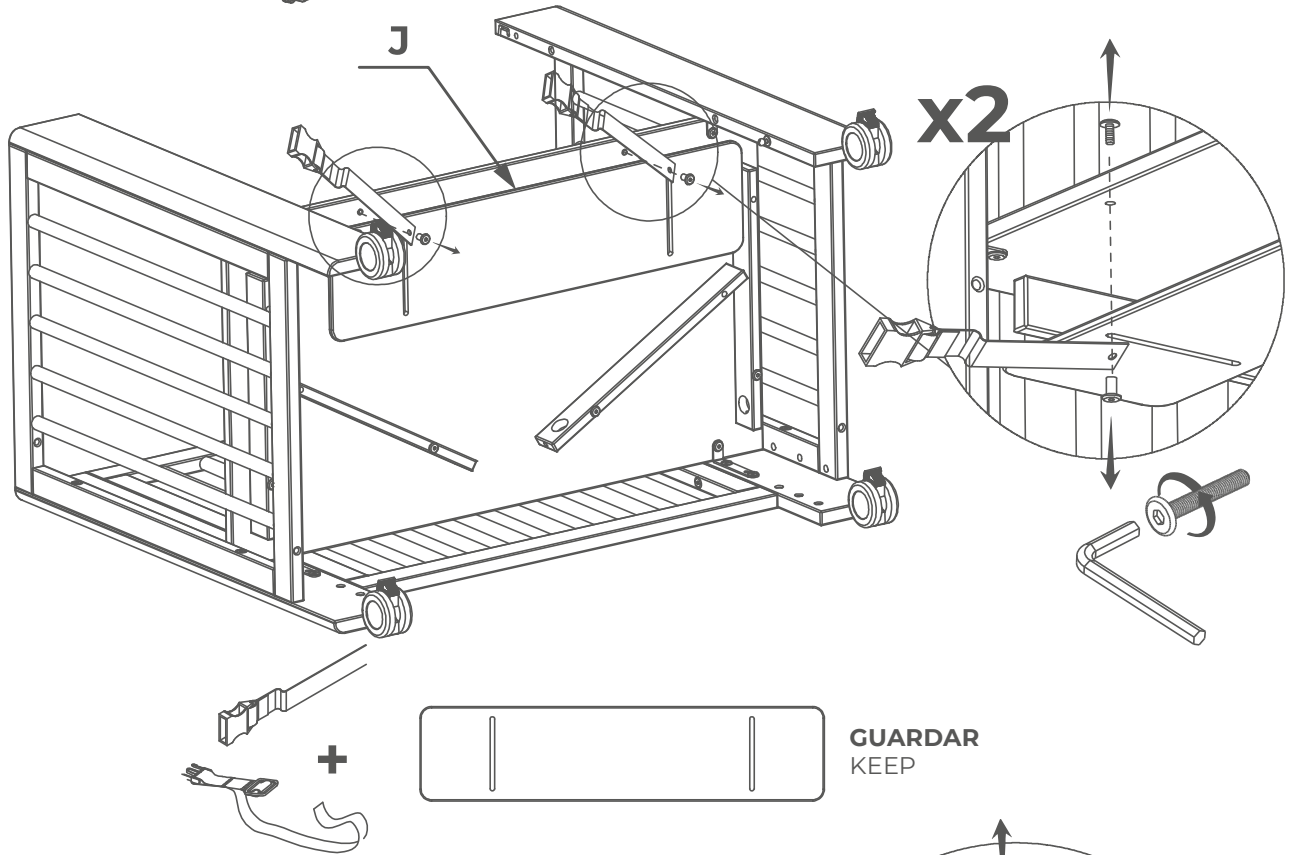

2 ALLEN 4MM

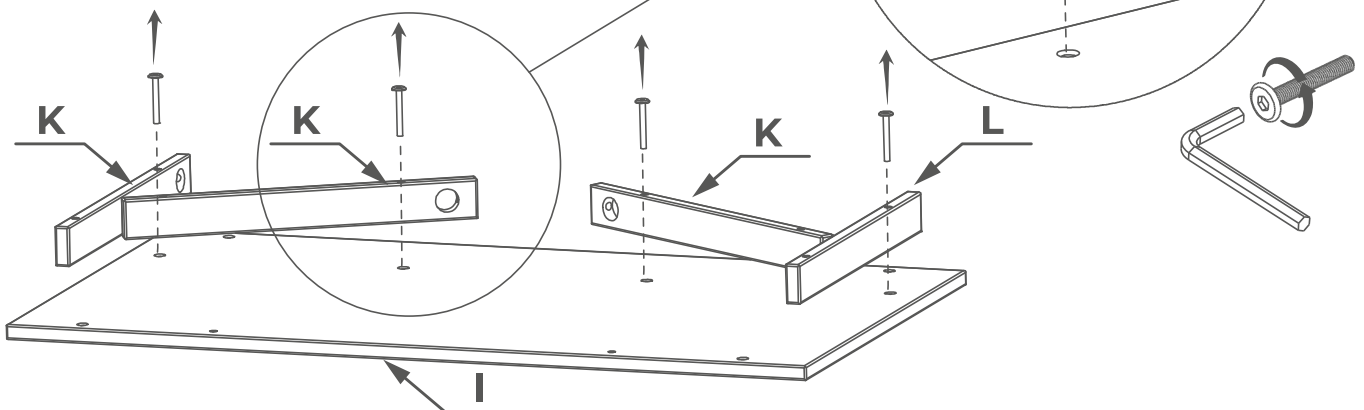
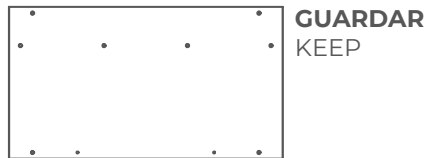

3 ALLEN 4MM

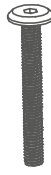

C06545
X8 (M6X50)



C08300
X10 (M6X30)

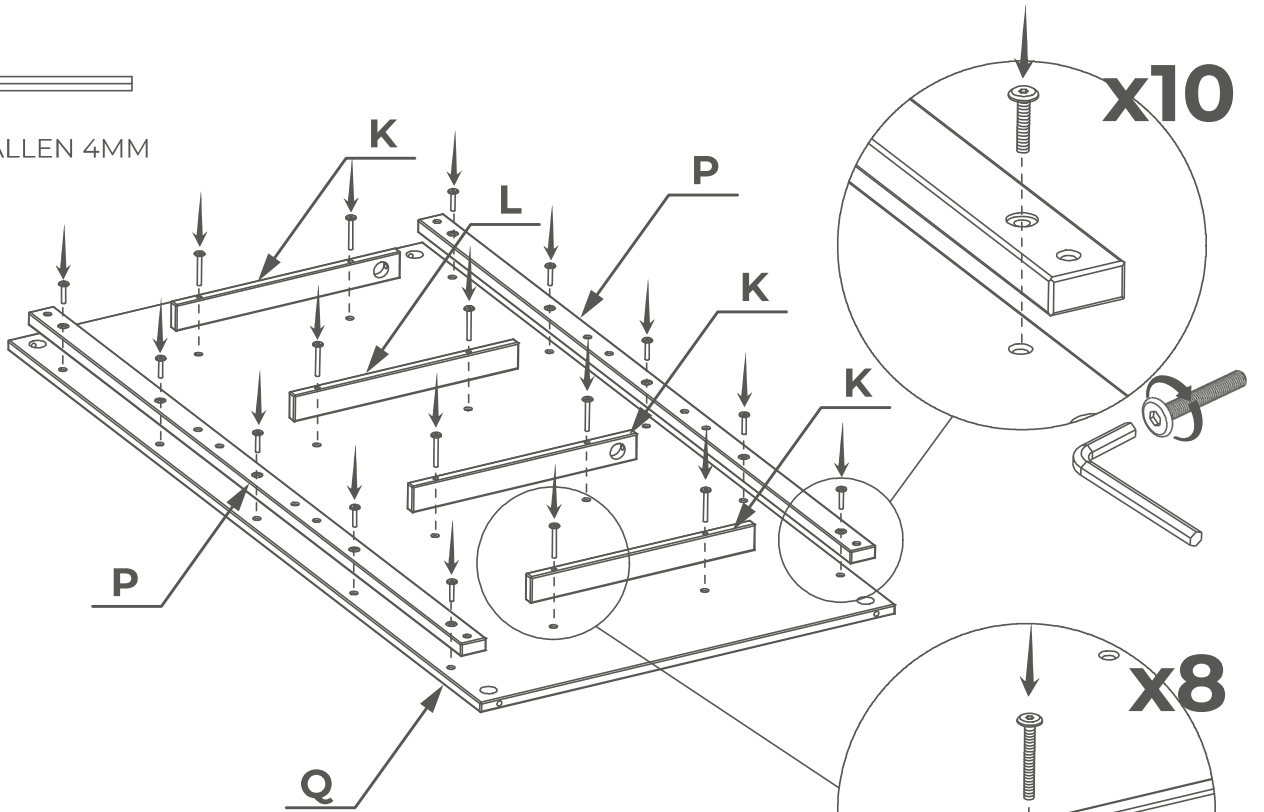

4 ALLEN 4MM

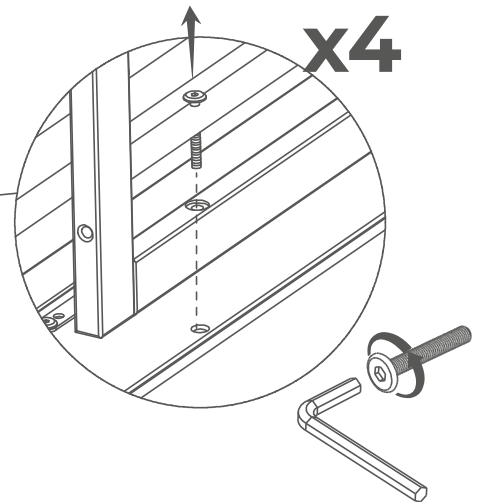
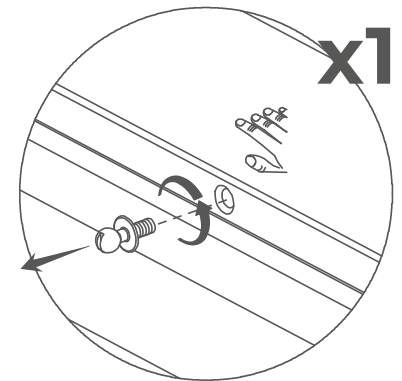
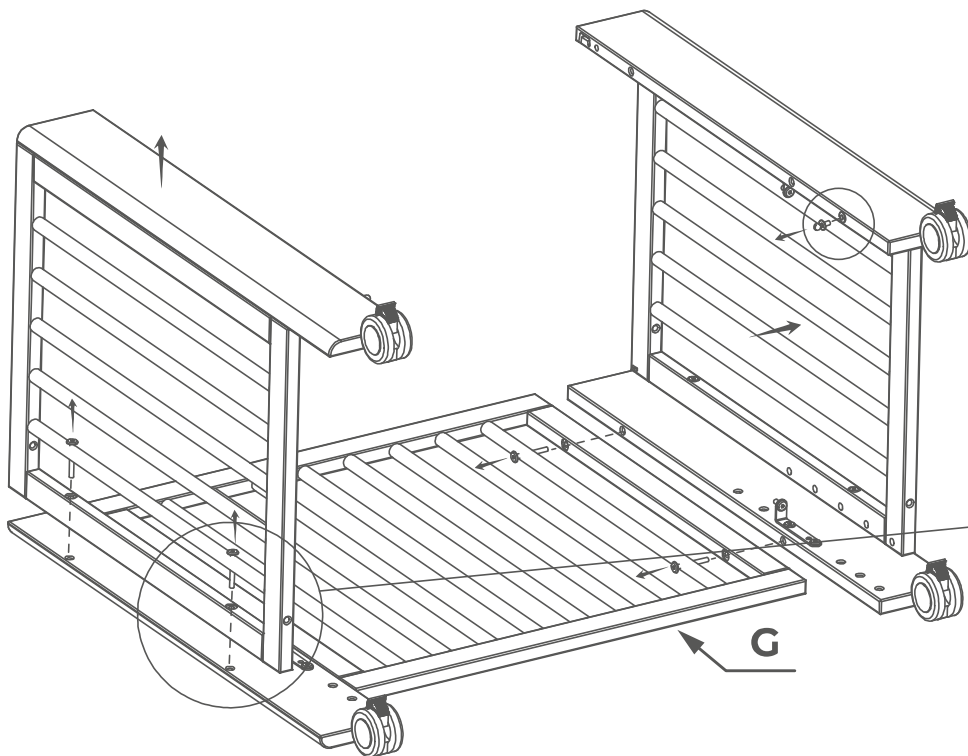

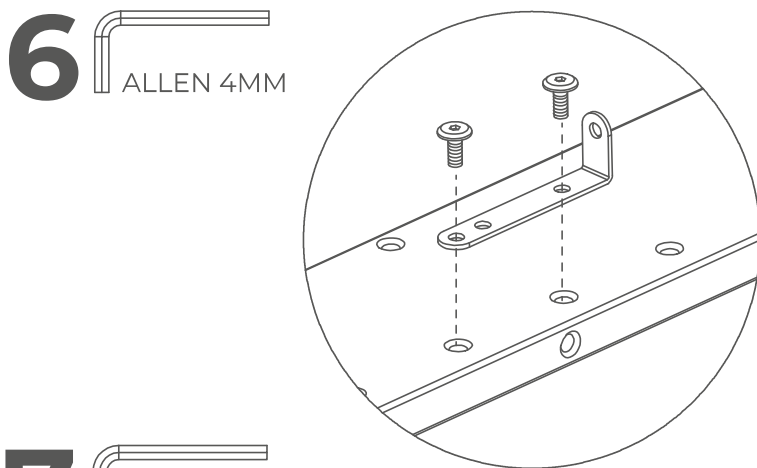
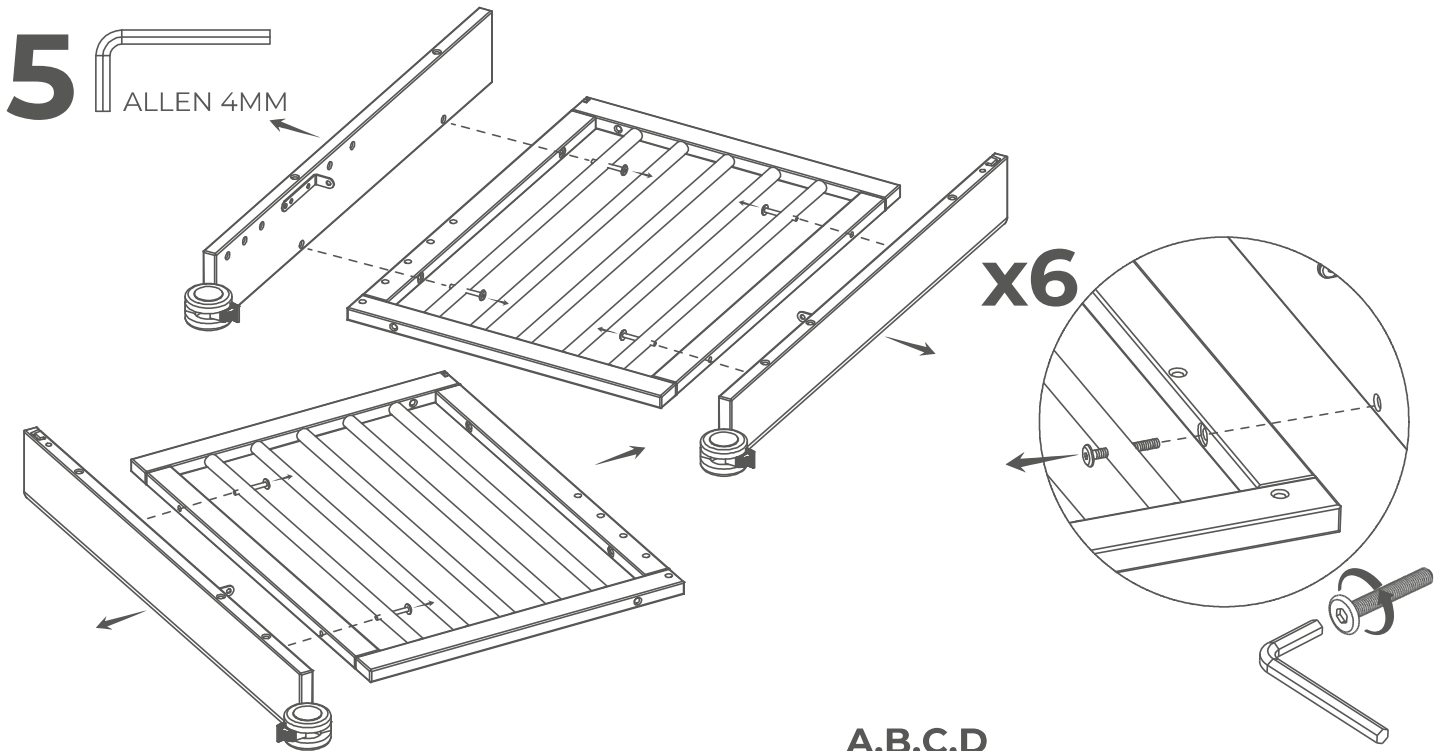

A,B,C,D



MEDIDAS CON RUEDAS INCLUIDAS
Desde parte superior del somier al suelo
MEASUREMENTS WITH WHEELS INCLUDED
From the top of the bed base to the floor

- 7+6=525mm
- 6+5=461mm
- 5+4=397mm
- 4+3=333mm
- 3+2=269mm
- 2+1=221mm

7

ALLEN 4MM

C07915
X2 (M6X15)



C15247
X2

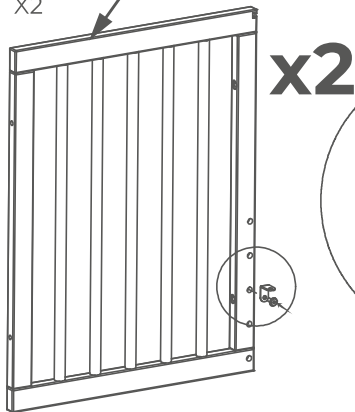

- 7+6
- 6+5
- 5+4
- 4+3
- 3+2

2+1

C07915
X2 (M6X15)



C15246
X2

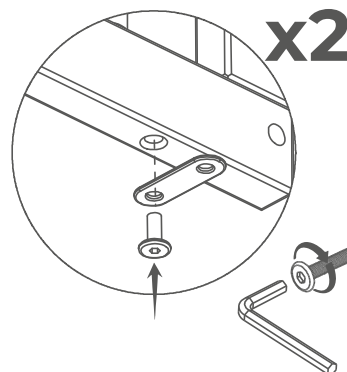

E,F

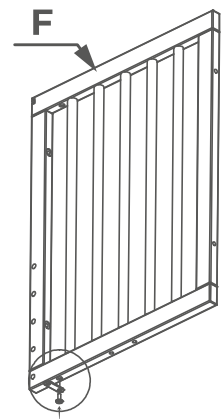
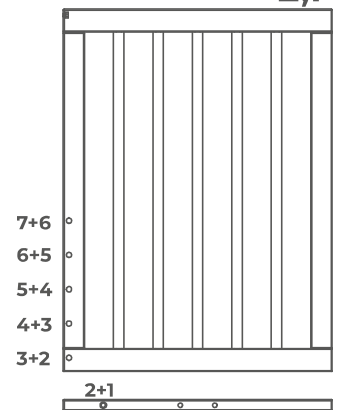

8

ALLEN 4MM

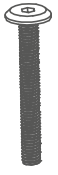

C06545
X6(M6X50)

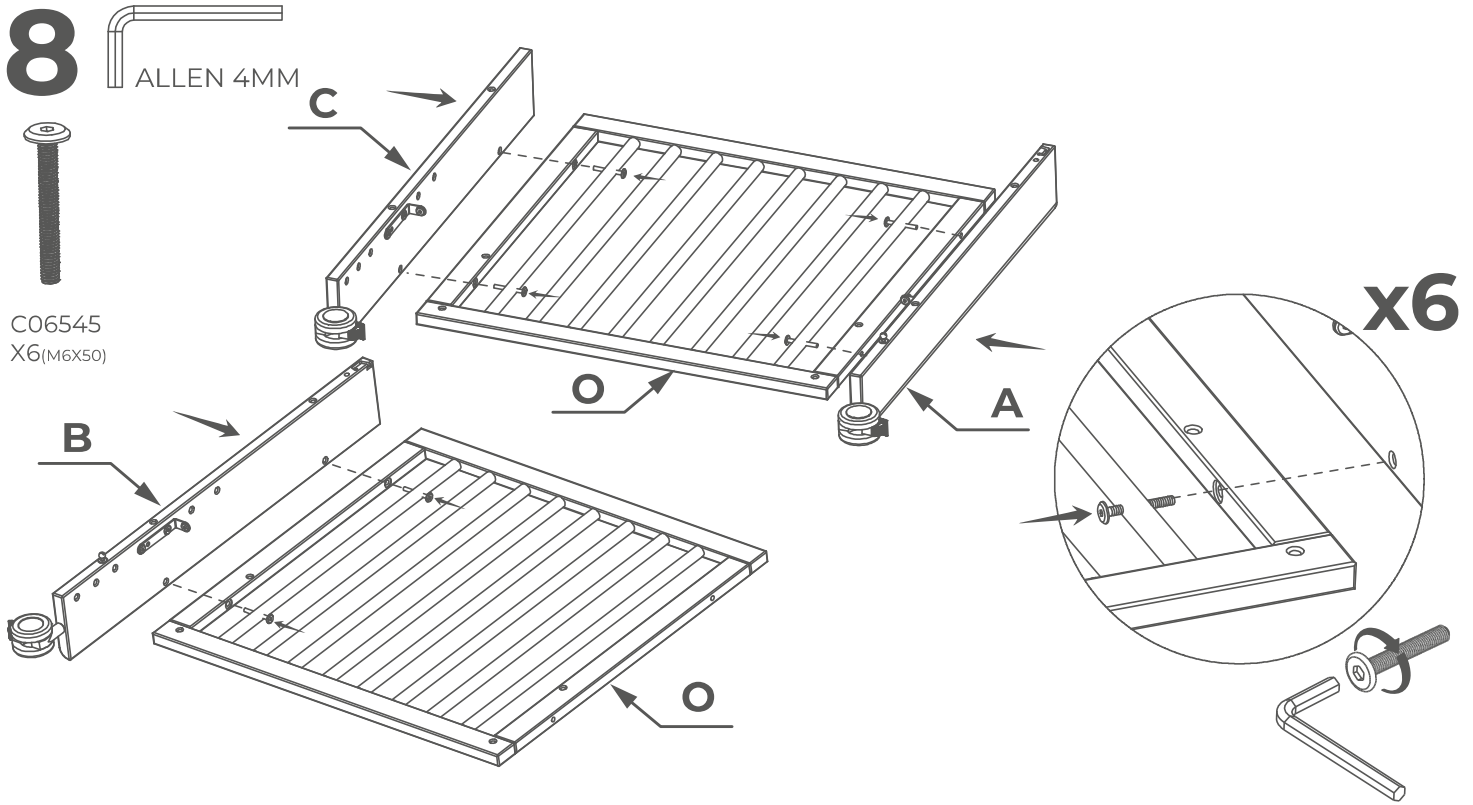

9

ALLEN 4MM X2

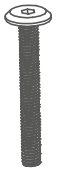

C06545
X2(M6X50)



C07915
X2(M6X15)



C09524
X2(M6X30)



C15482
X1

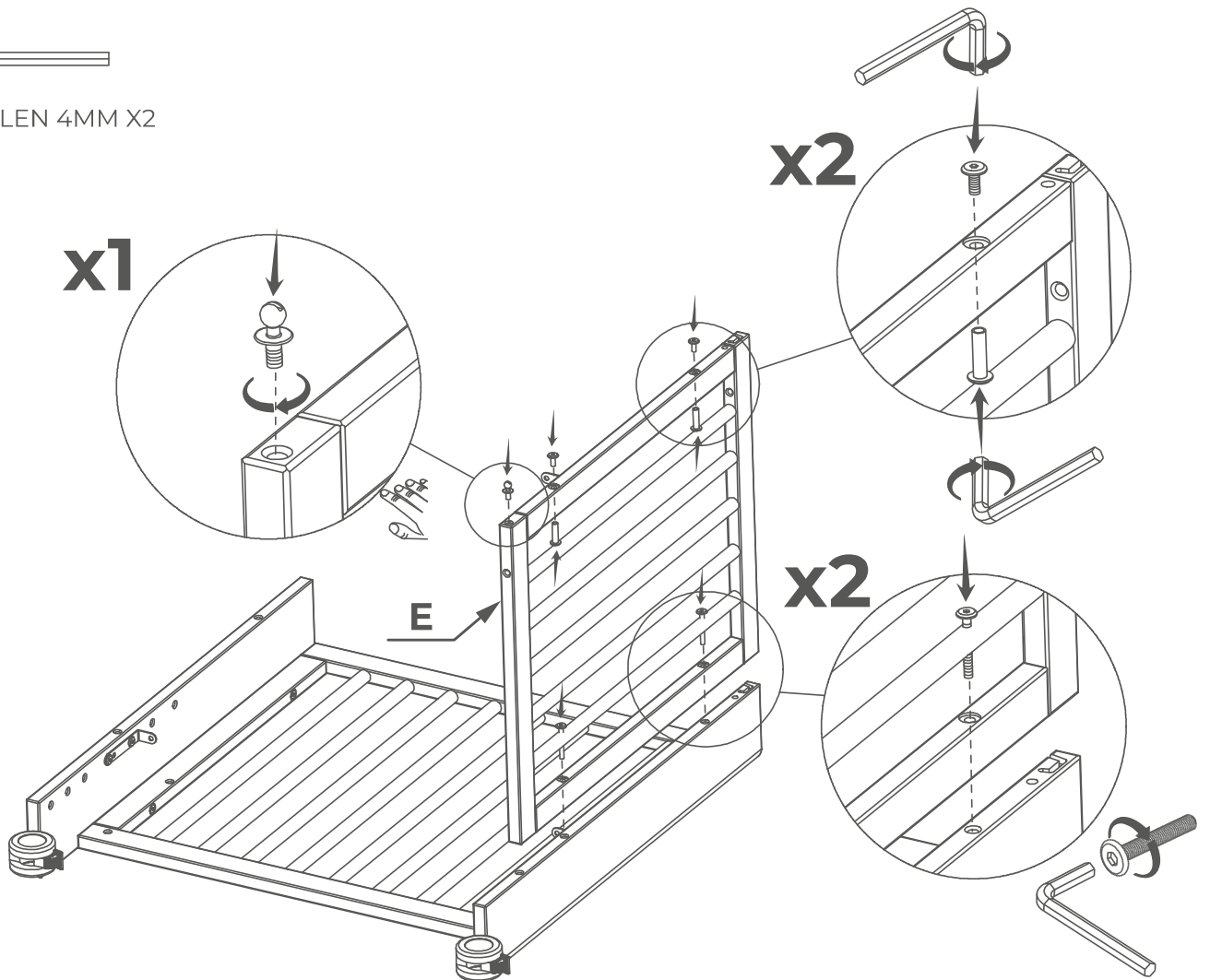

10

ALLEN 4MM X2

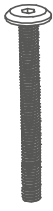

C05556
X2(M6X60)



C09524
X2(M6X30)

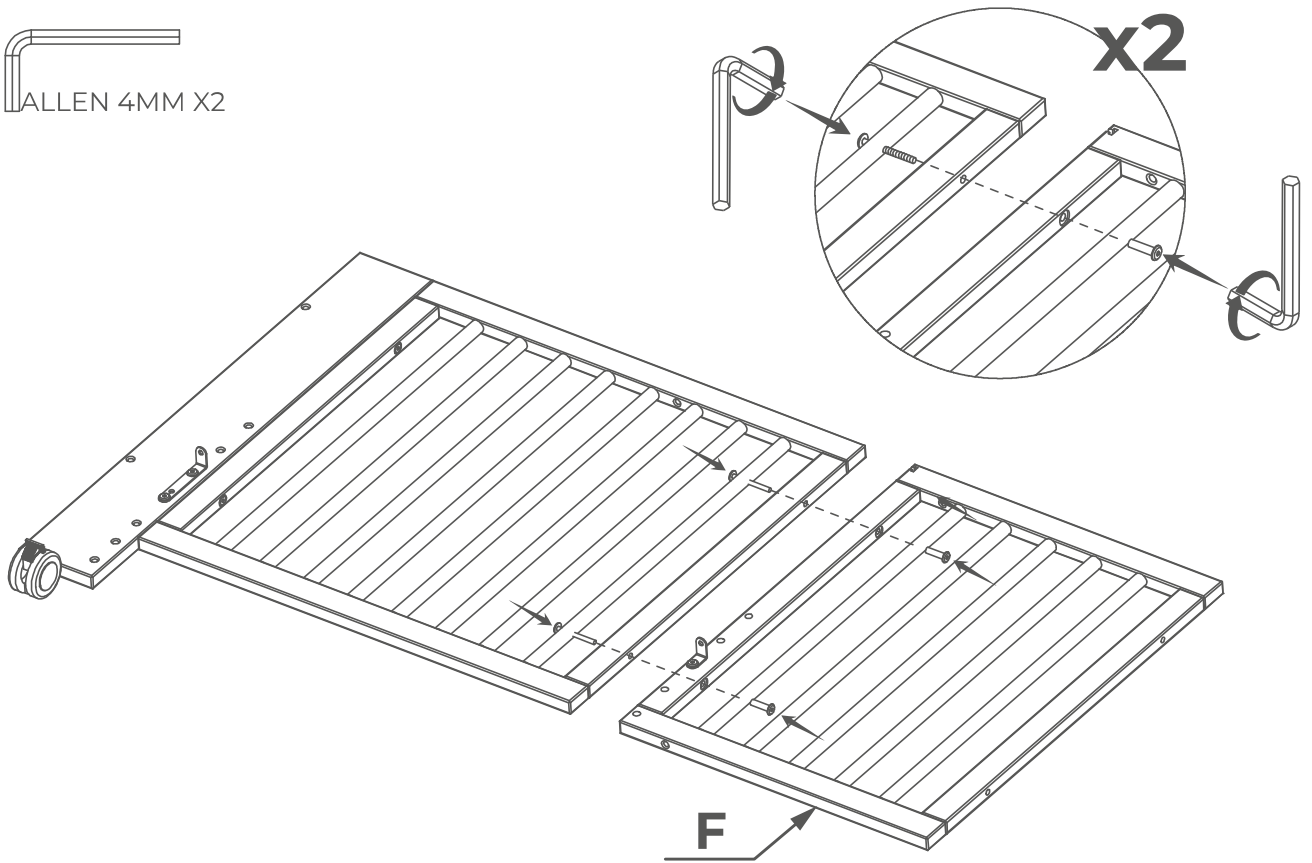

11

ALLEN 4MM

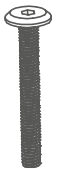

C06545
X4(M6X50)

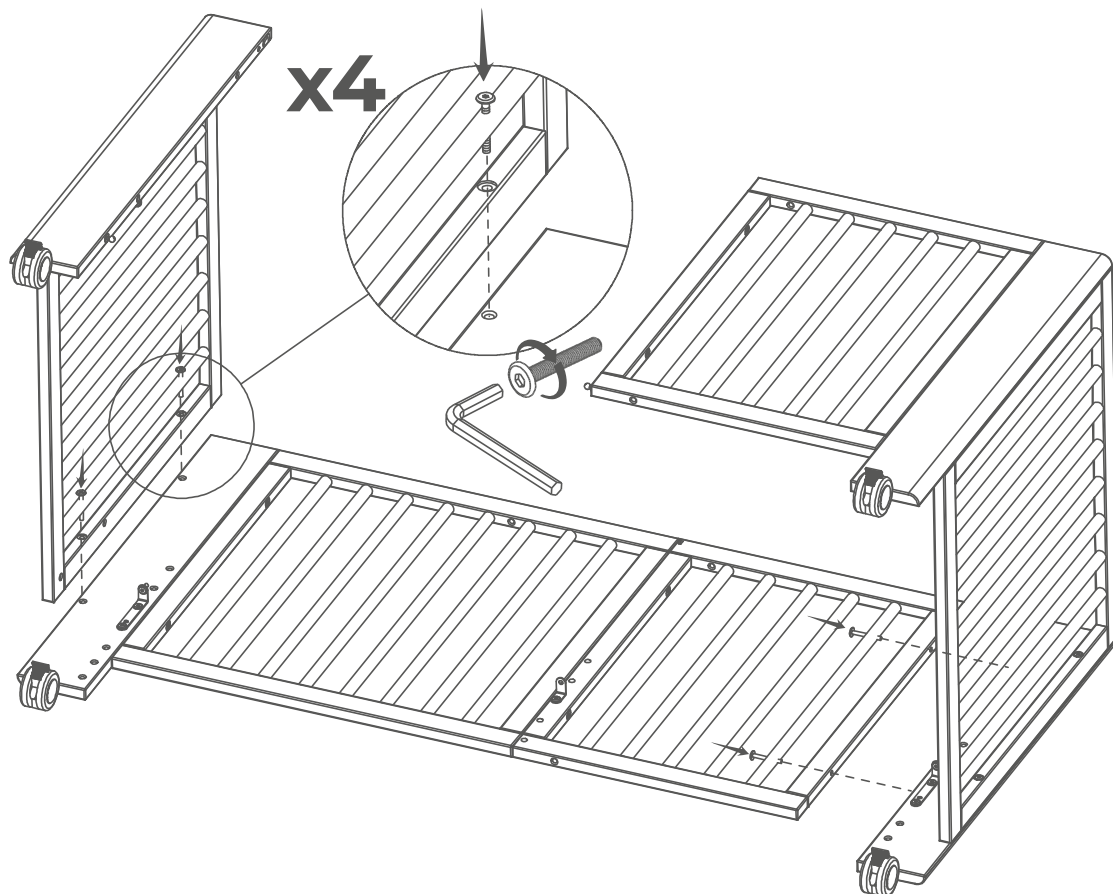

12 ALLEN 4MM



C07915
X6 (M6X15)

1°
x4

2°
x2

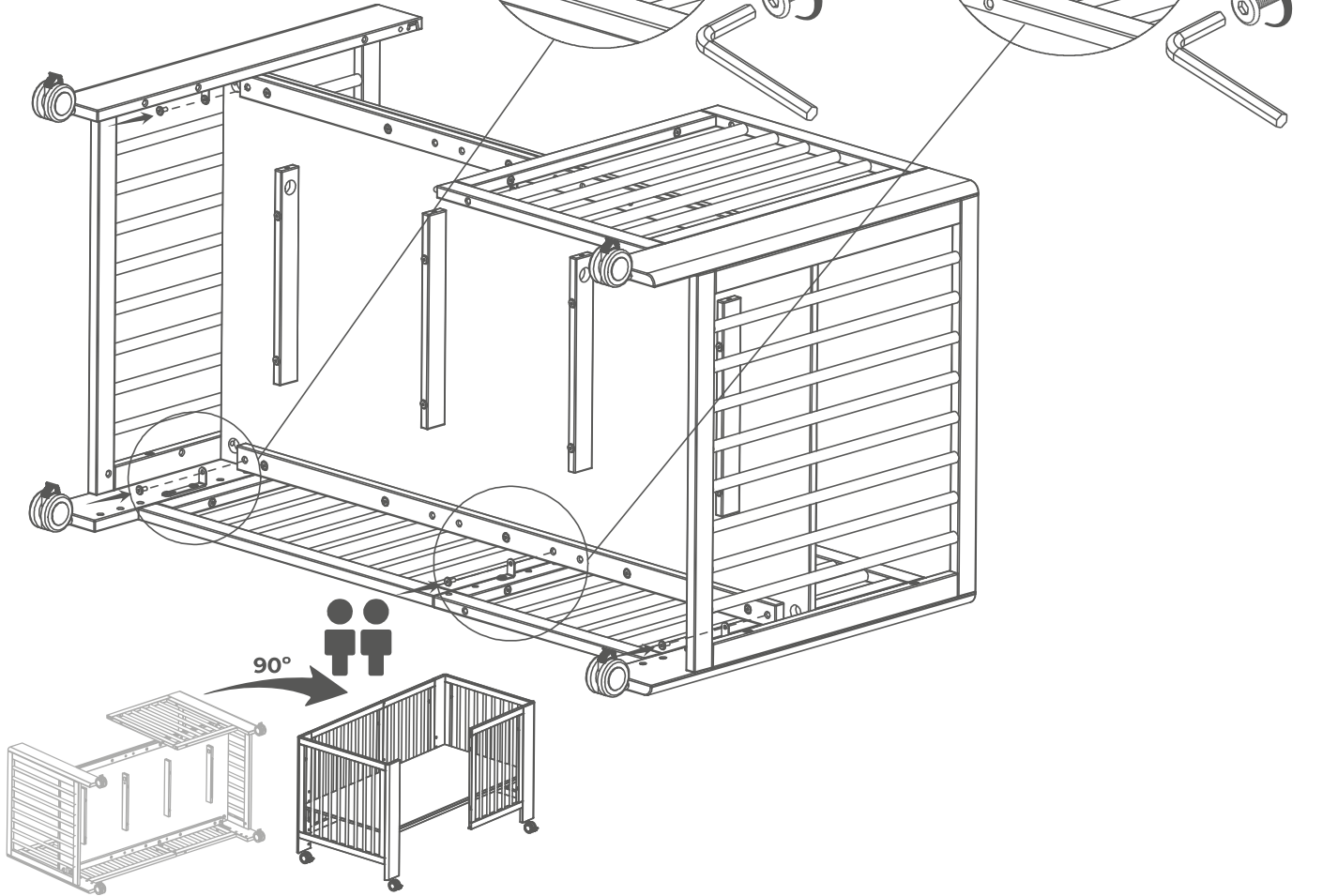

COLOCACIÓN LATERAL MÓVIL
MOBILE SIDE PLACEMENT

micuna CARA DELANTERA
made with love FRONT FACE

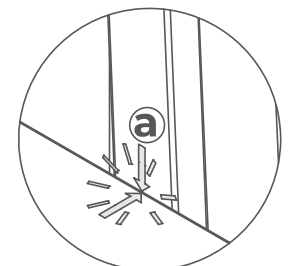
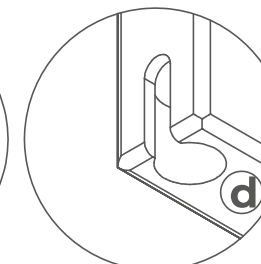
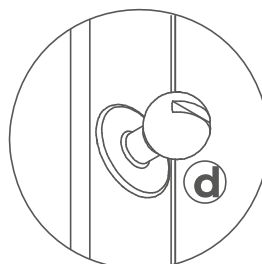
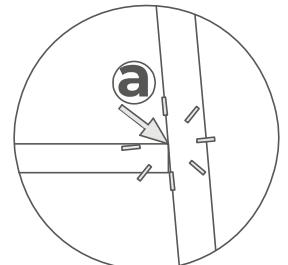
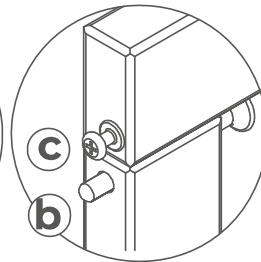
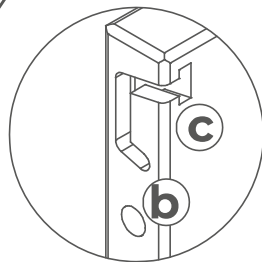
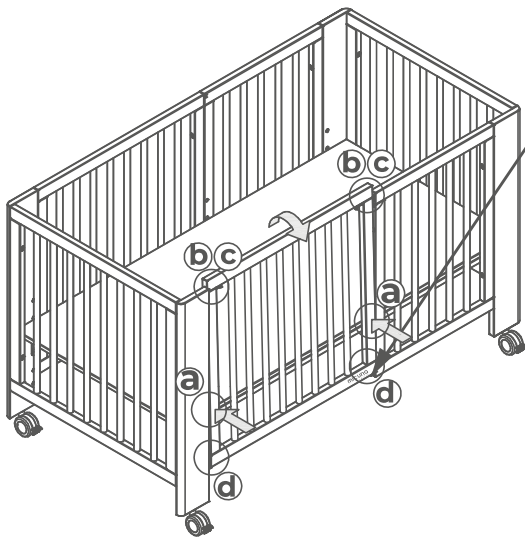

13

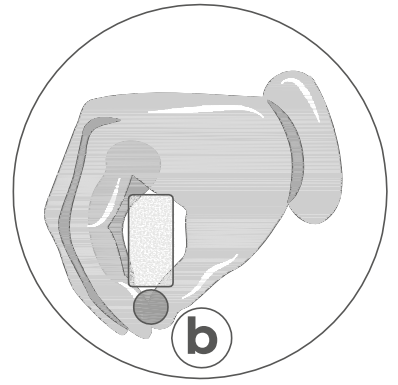
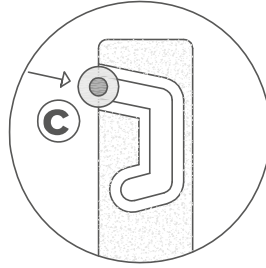
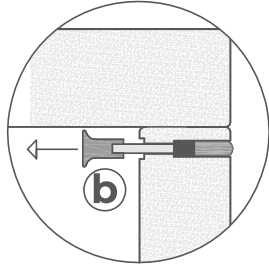
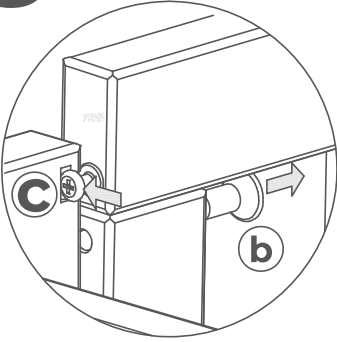

14

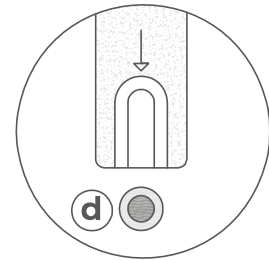
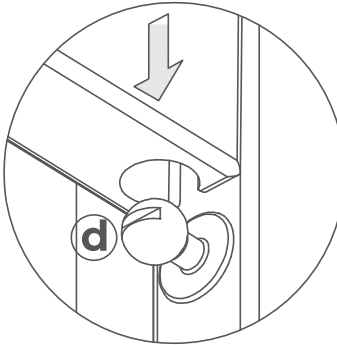
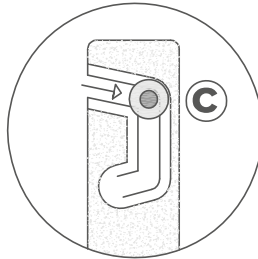
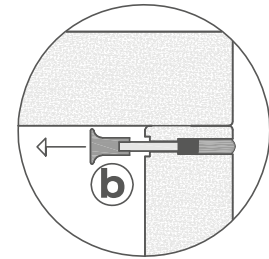
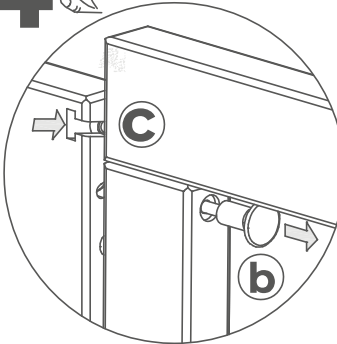

15

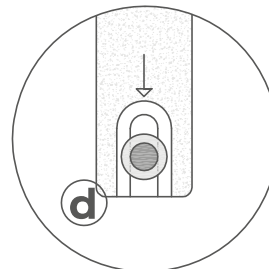
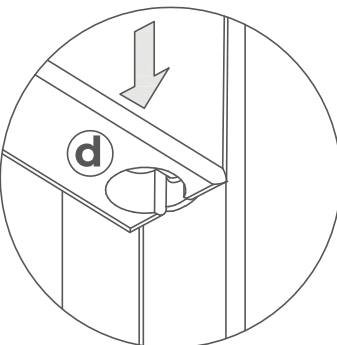
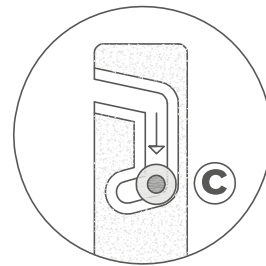
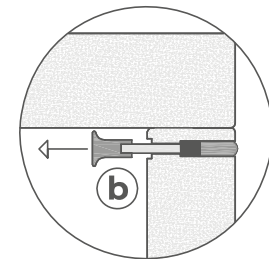
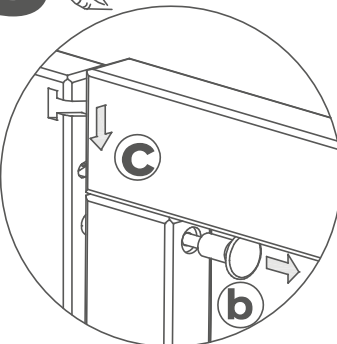

16

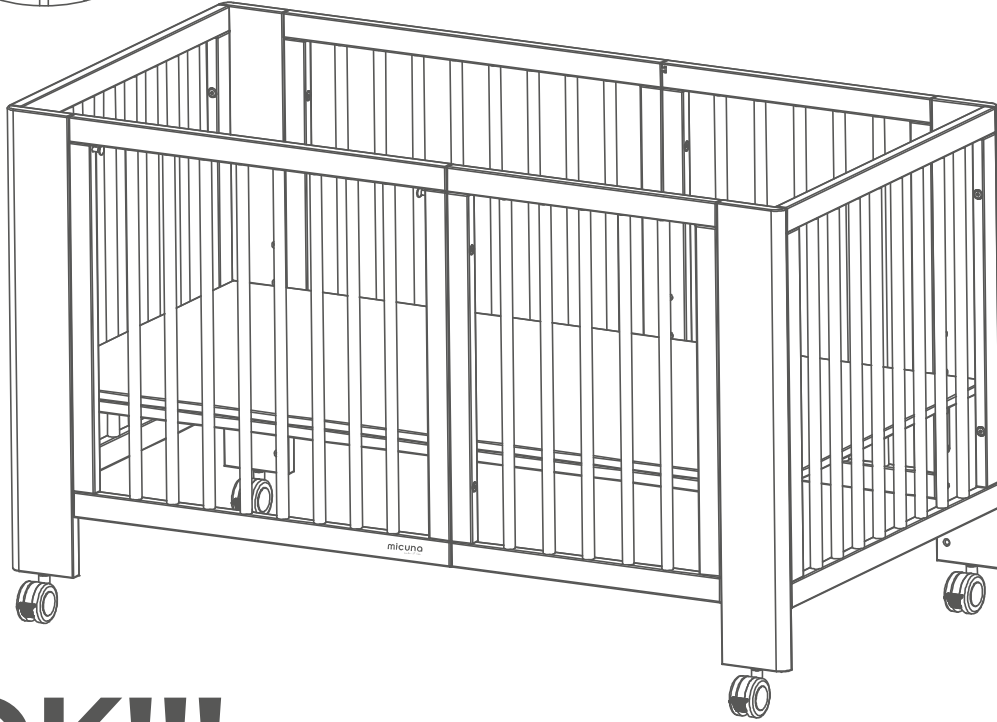
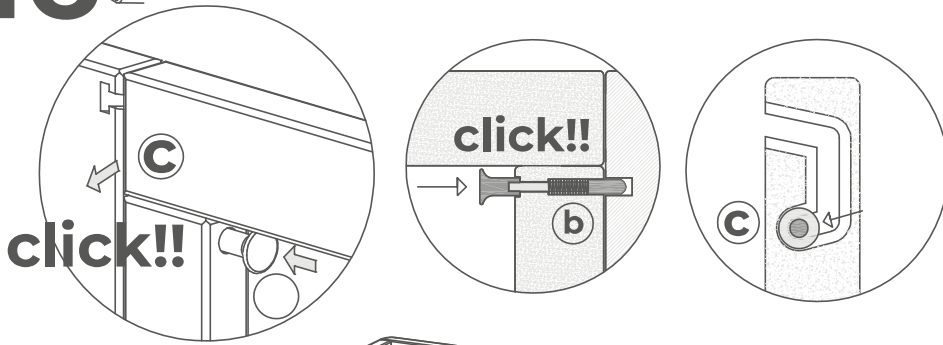

OK!!!

CUNA CON RUEDAS
CRADLE WITH WHEELS

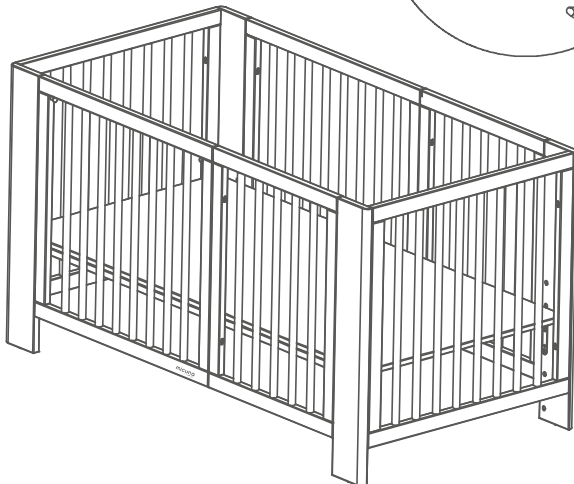
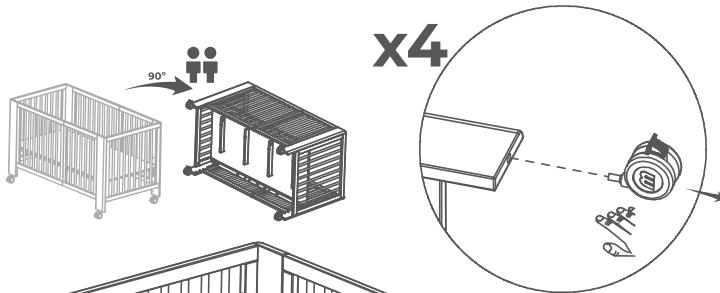

CUNA SIN RUEDAS
CRIB WITHOUT WHEELS

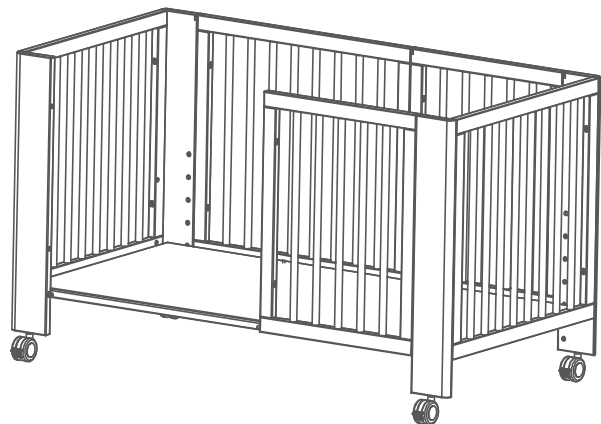

CUNA GATERA
CAT CRADLE

EXTRACCIÓN LATERAL MÓVIL
MOBILE SIDE EXTRACTION

SOFÁ JUNIOR
JUNIOR SOFA

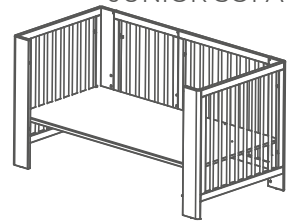

SOFÁ MONTESSORI
MONTESSORI SOFA

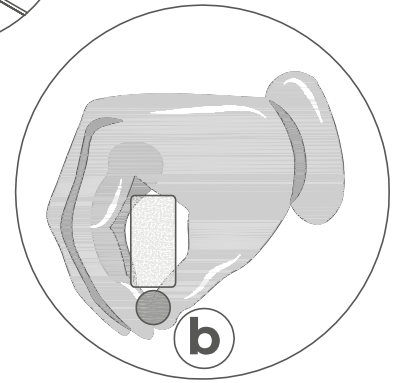
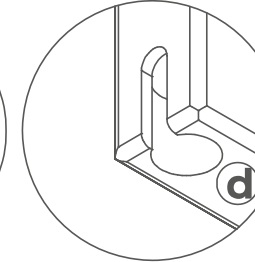
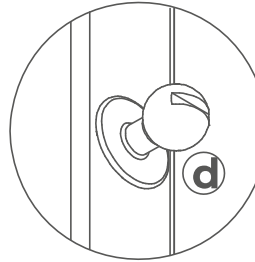
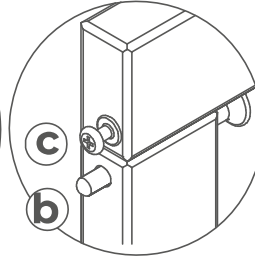
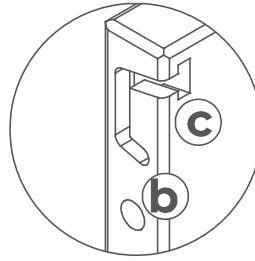
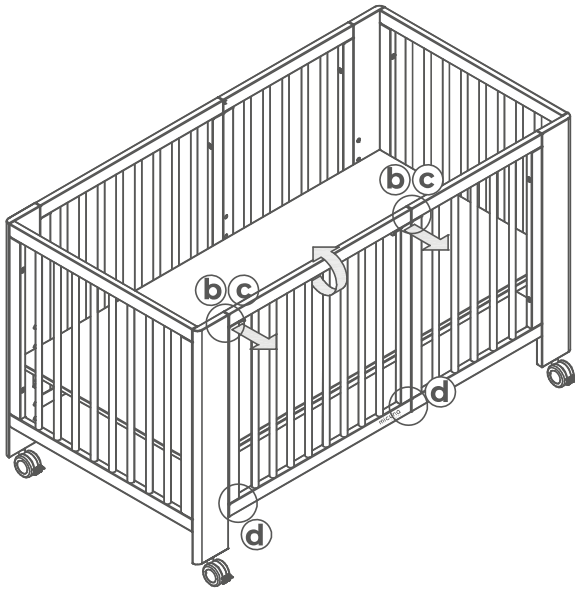
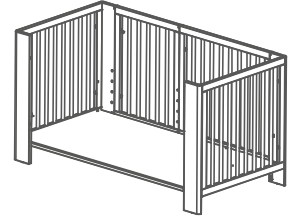

1

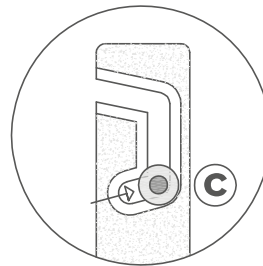
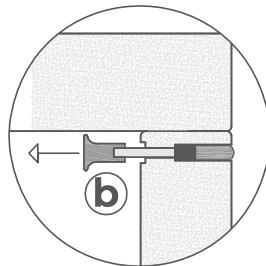
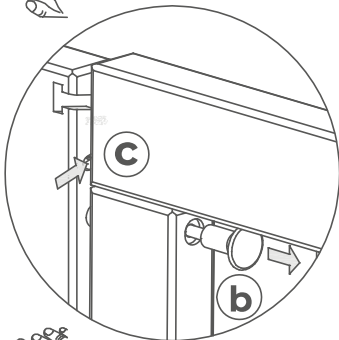

2

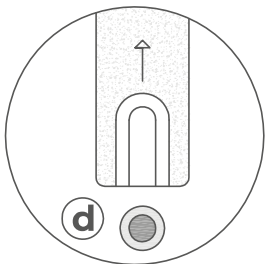
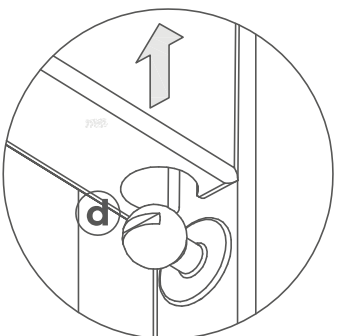
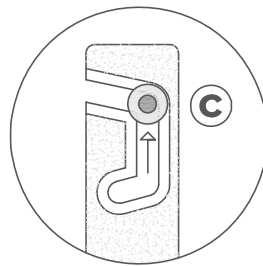
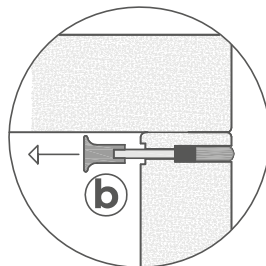
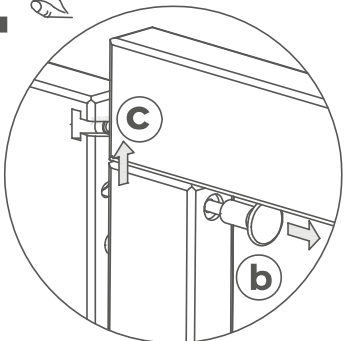

3 

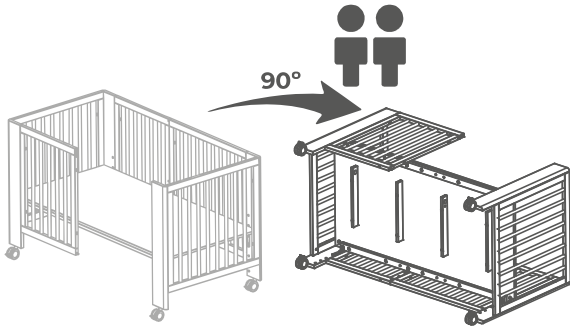
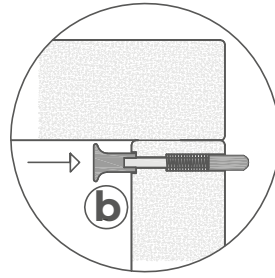
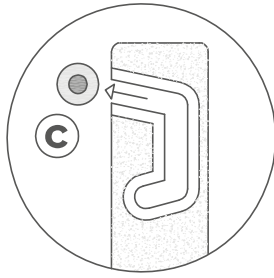
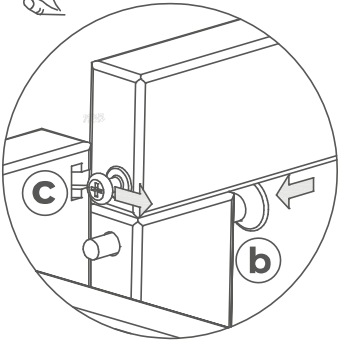

4

 ALLEN 4MM

x4

x2

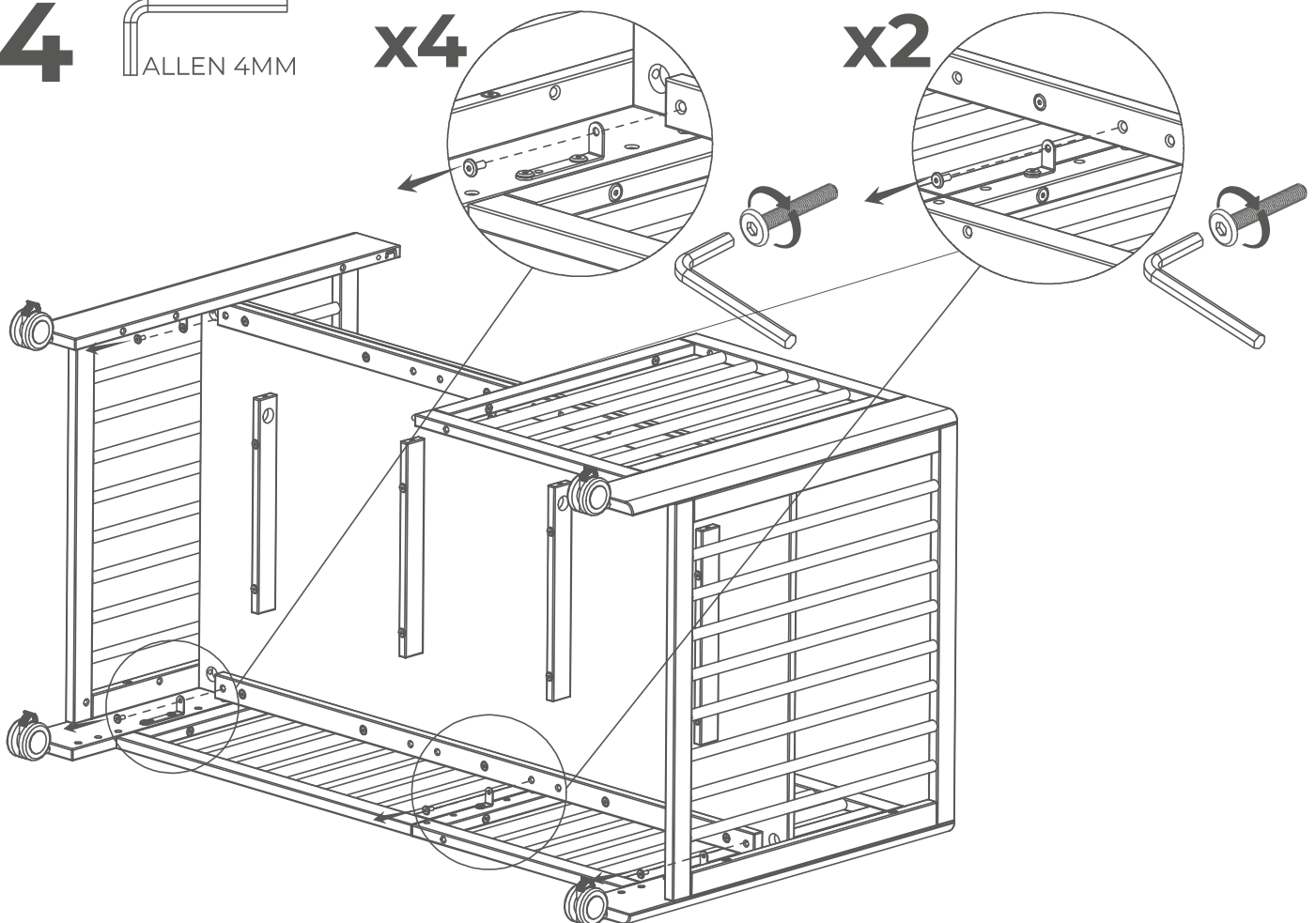

5

ALLEN 4MM X2

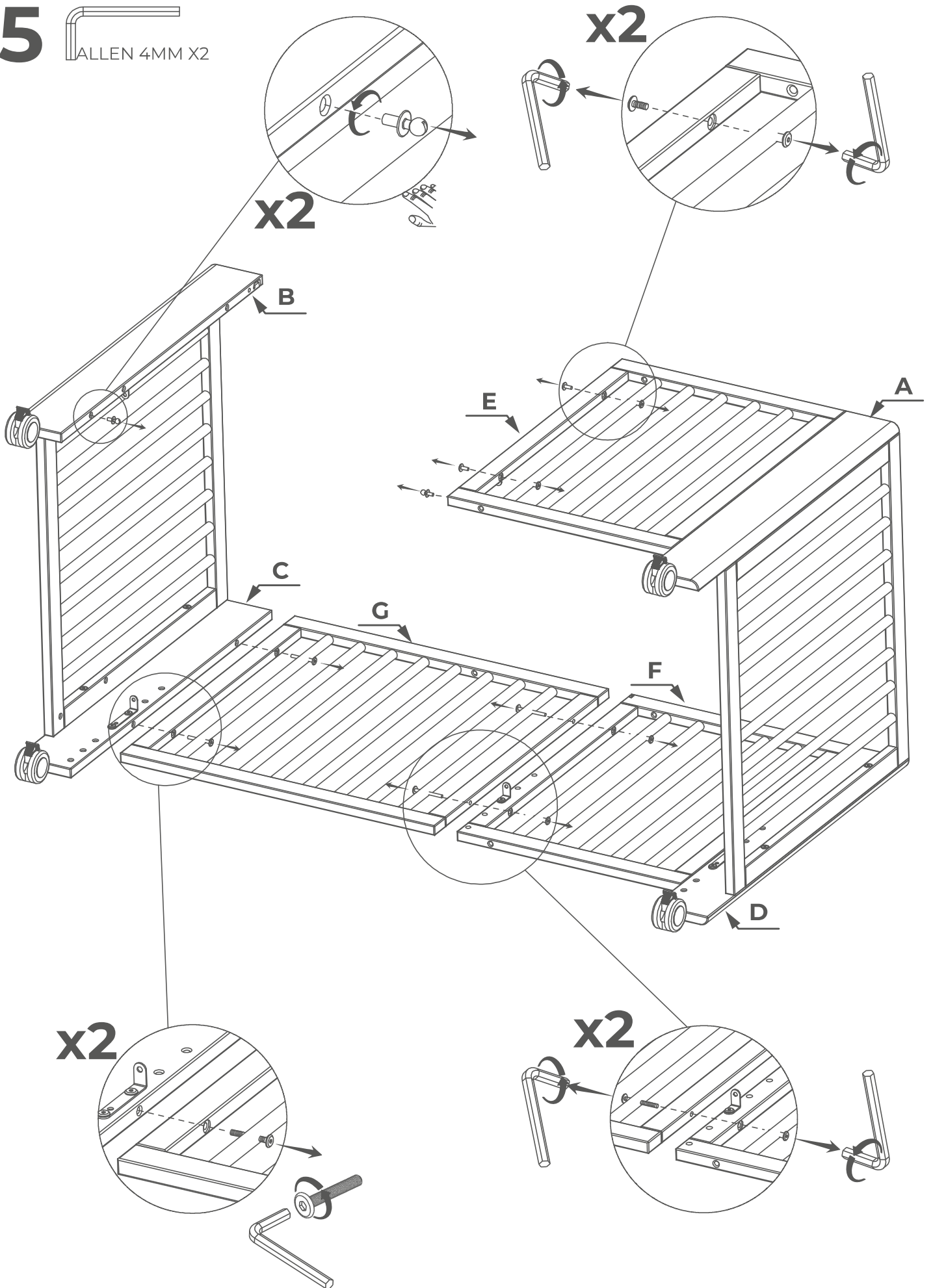

6 ALLEN 4MM



C10313
X4

MEDIDAS CON RUEDAS INCLUIDAS
Desde parte superior del somier al suelo
MEASUREMENTS WITH WHEELS INCLUDED
From the top of the bed base to the floor
5+4=397mm SOFÁ JUNIOR
2+1=221mm SOFÁ MONTESSORI
5+4=397mm JUNIOR SOFA
2+1=221mm MONTESSORI SOFA

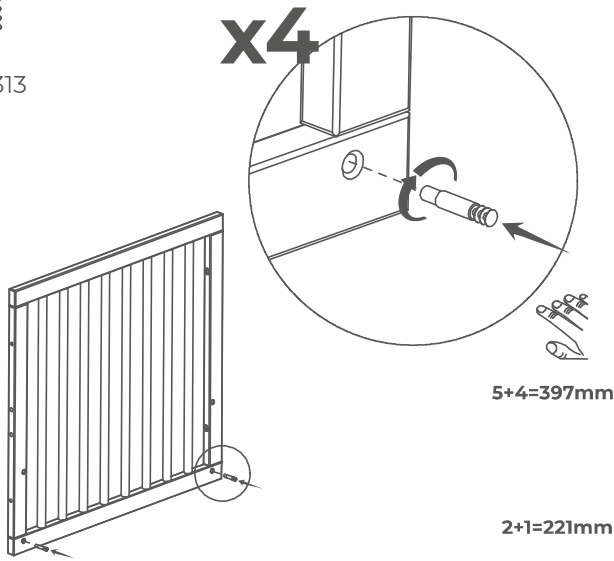

O x2

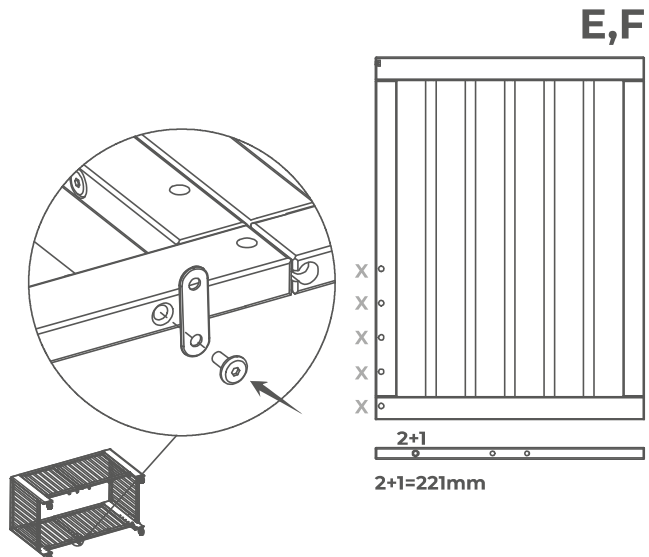
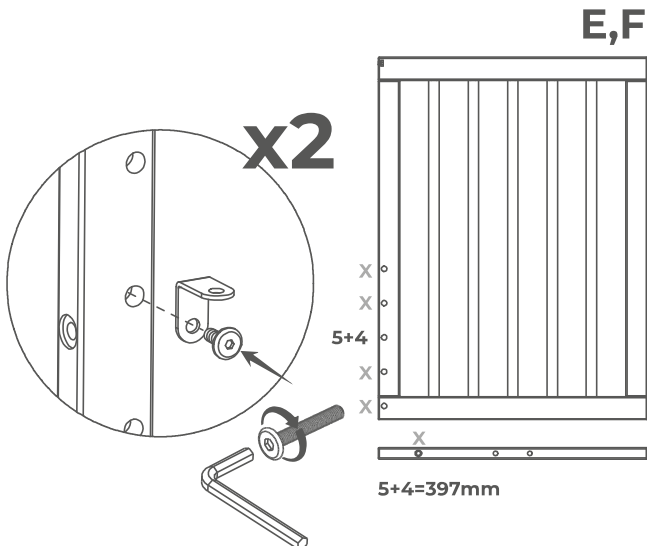
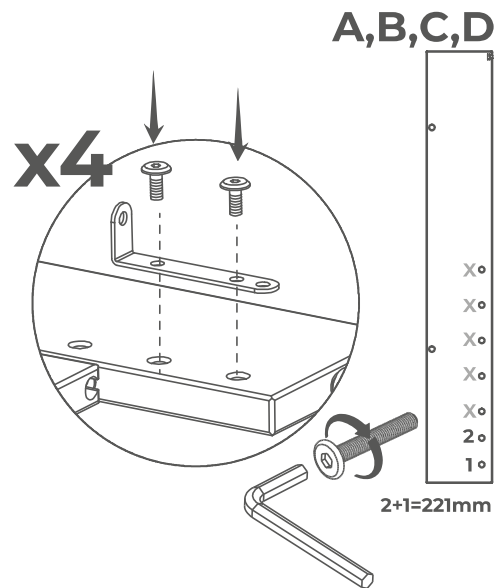
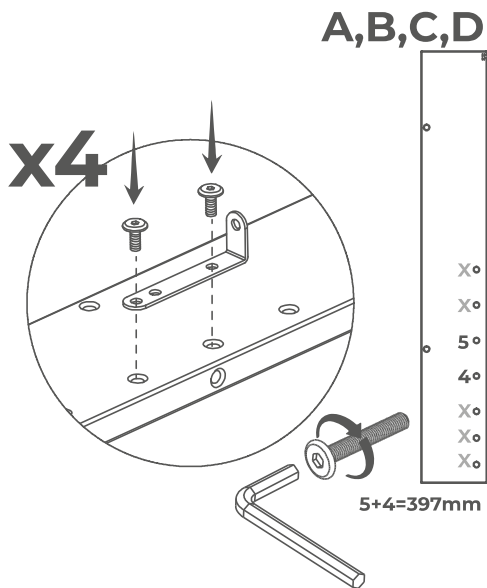
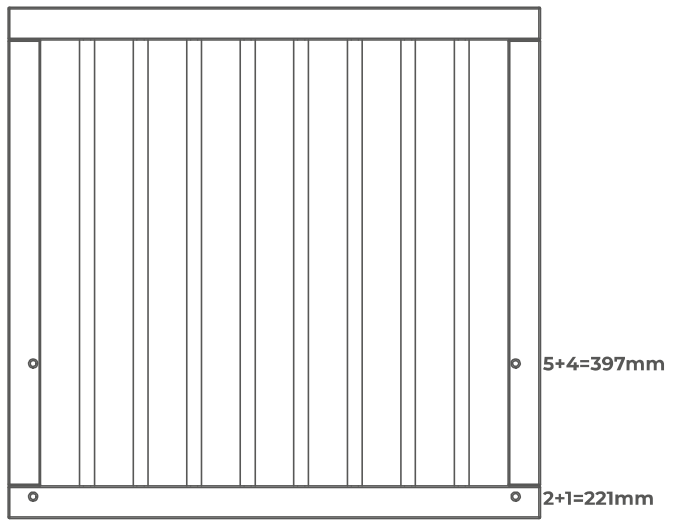

7 ALLEN 4MM X2

C05556
X2 (M6X60)

C09524
X4 (M6X30)

C07915
X6 (M6X15)

C15482
X2

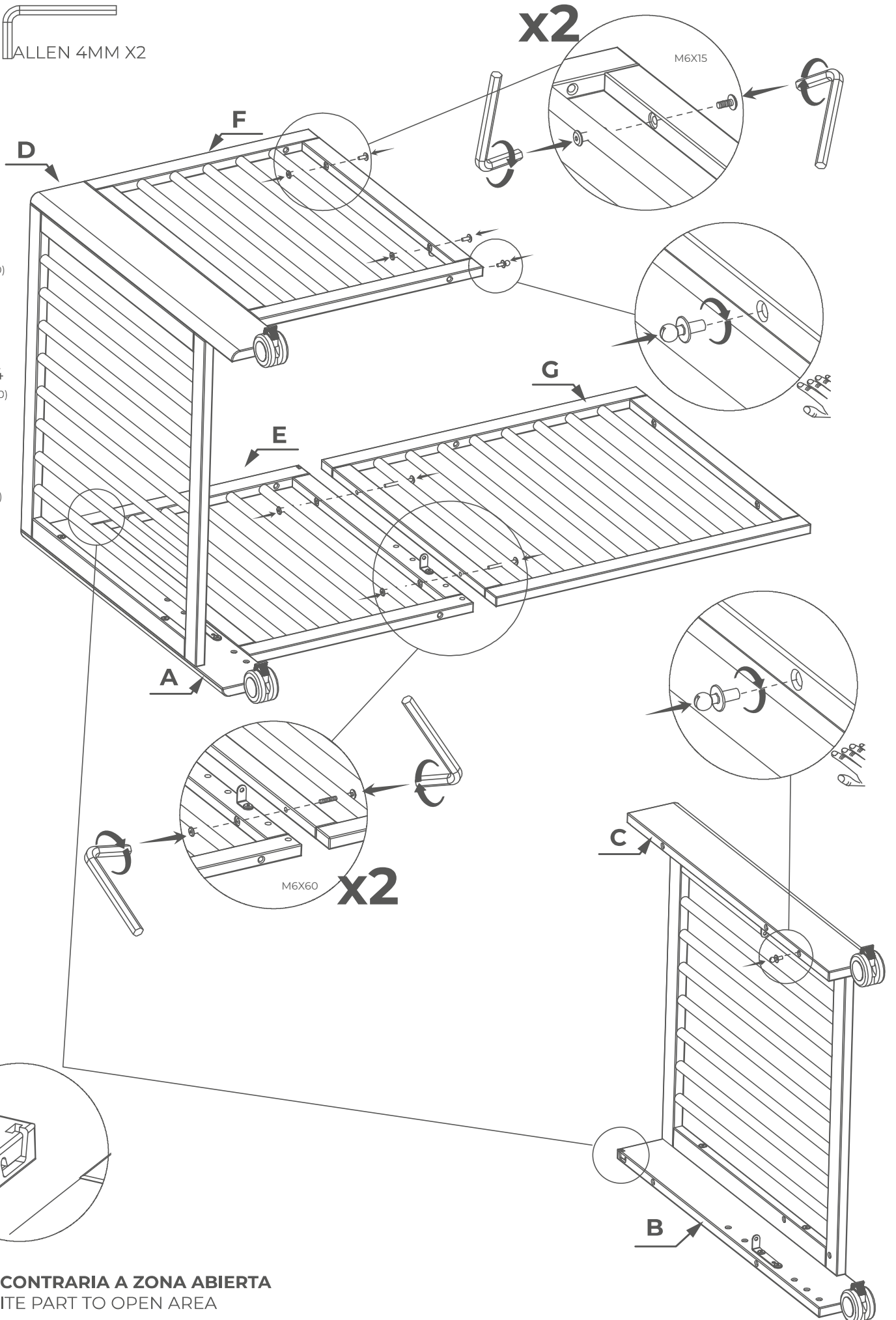

PARTE CONTRARIA A ZONA ABIERTA
OPPOSITE PART TO OPEN AREA

8



C07376
X4

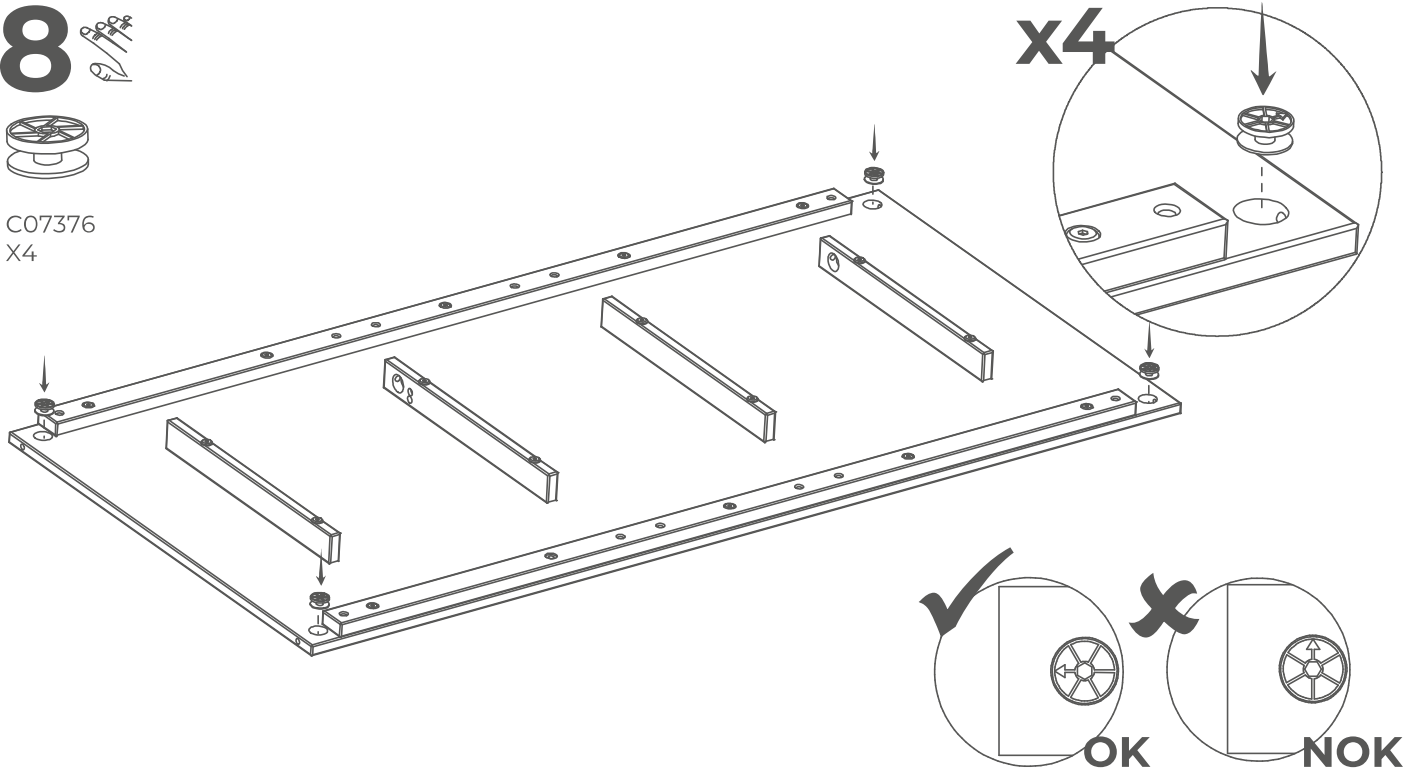

9

ALLEN 5MM

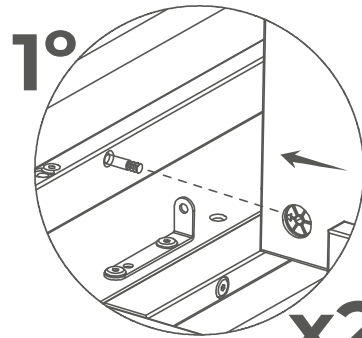

X2

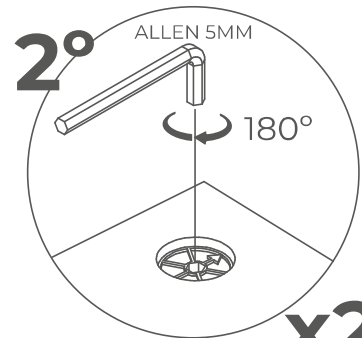

X2

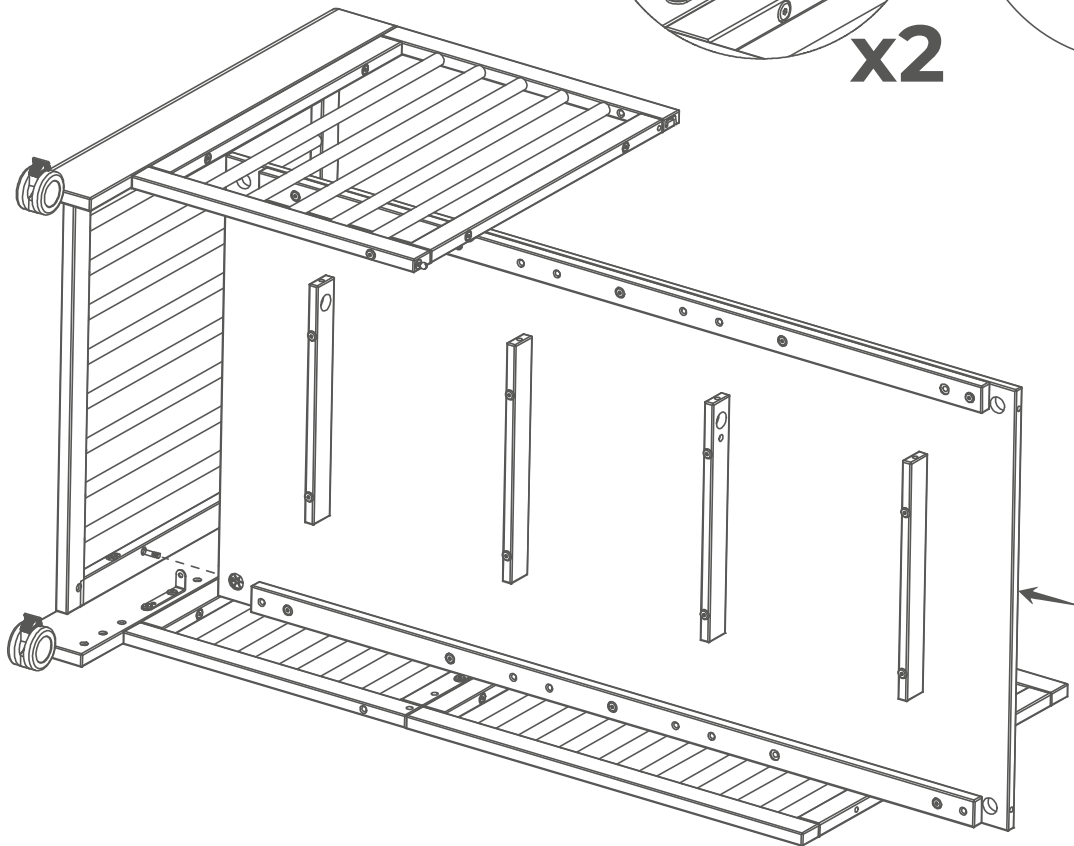

10

ALLEN 5MM

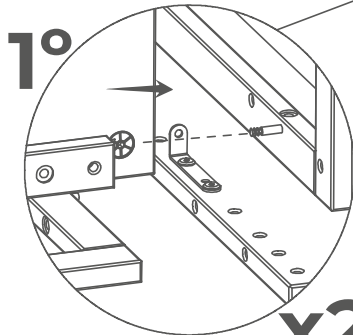
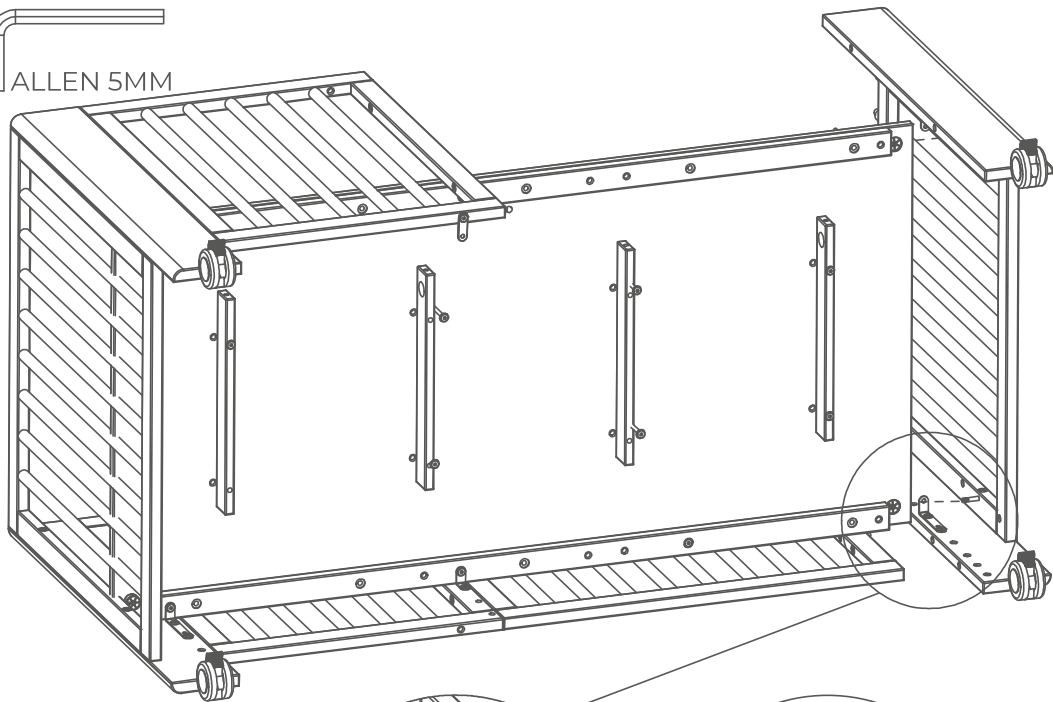

x2

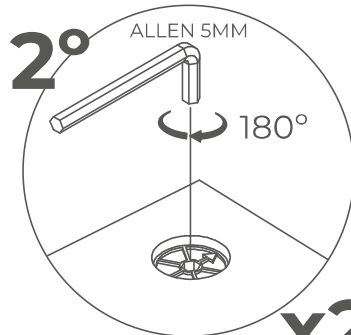

x2

11

ALLEN 4MM



C07915
X6(M6X15)

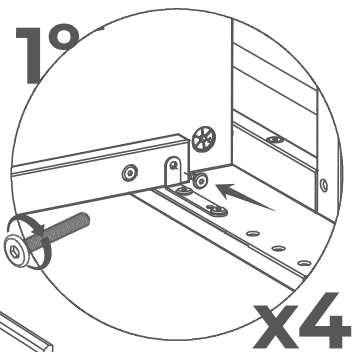
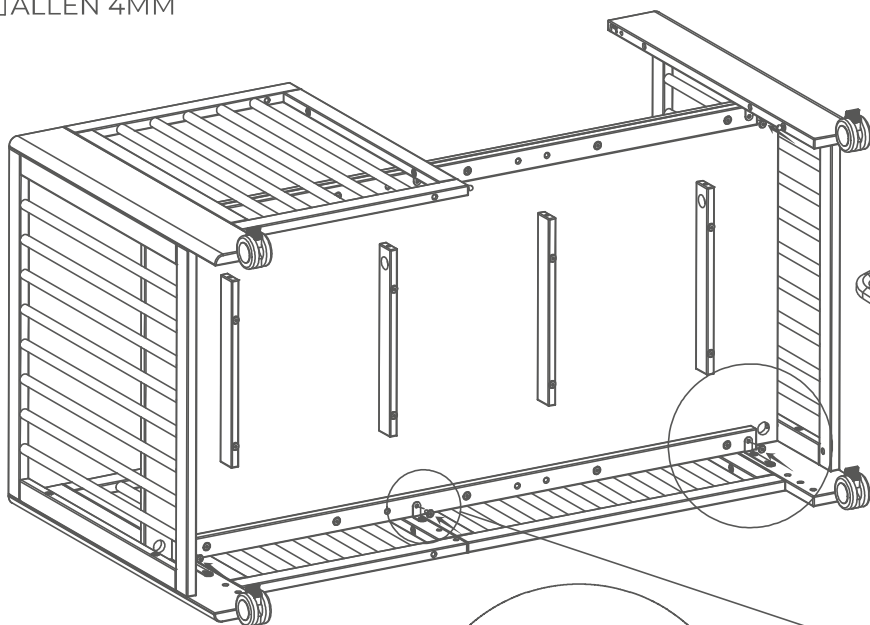

x4

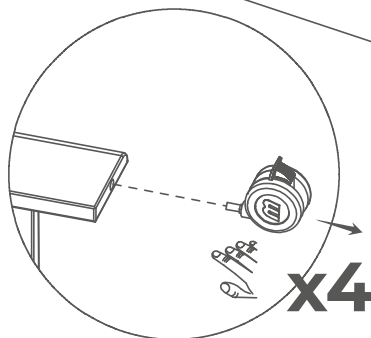

x4

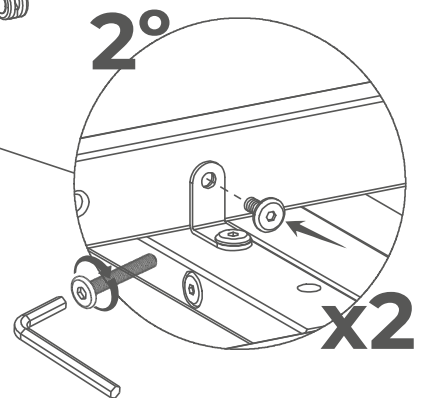

x2

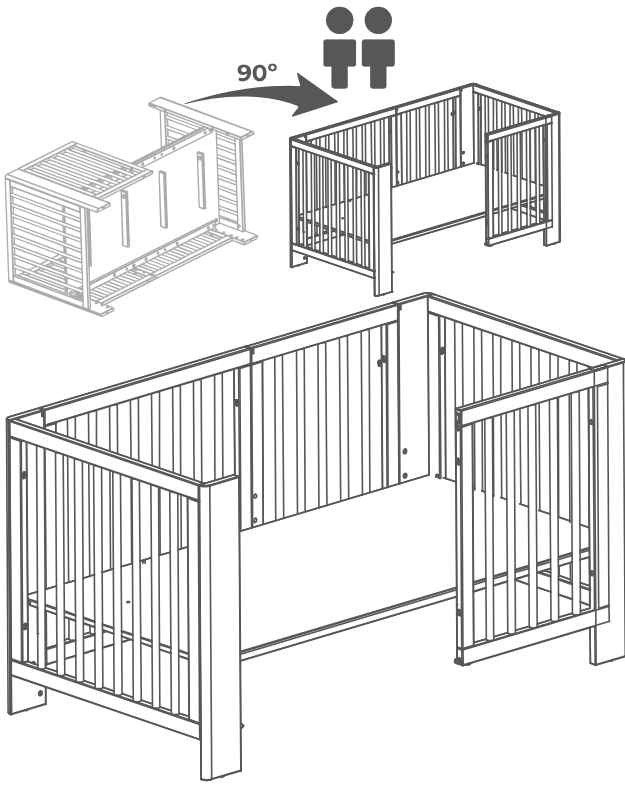

SOFÁ JUNIOR CON BARRERA
JUNIOR SOFA WITH BARRIER

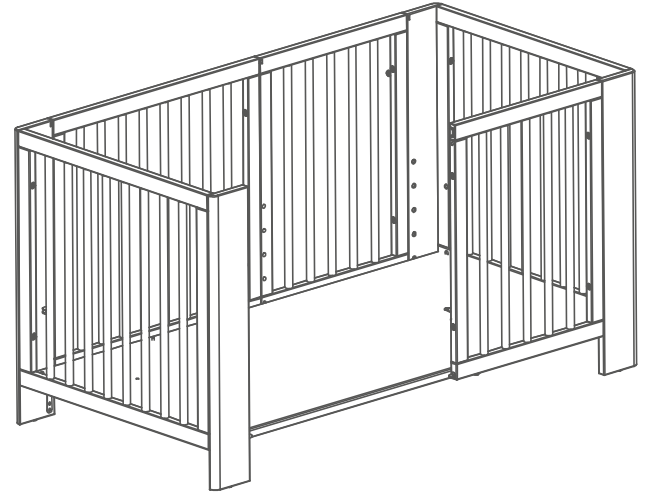

SOFÁ MONTESSORI CON BARRERA
MONTESSORI SOFA WITH BARRIER

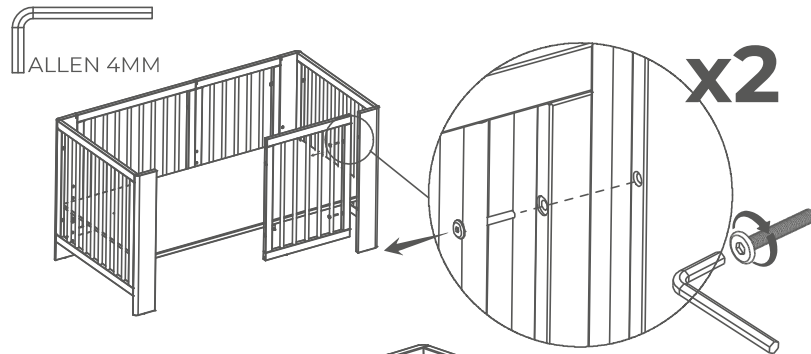

OK!!!

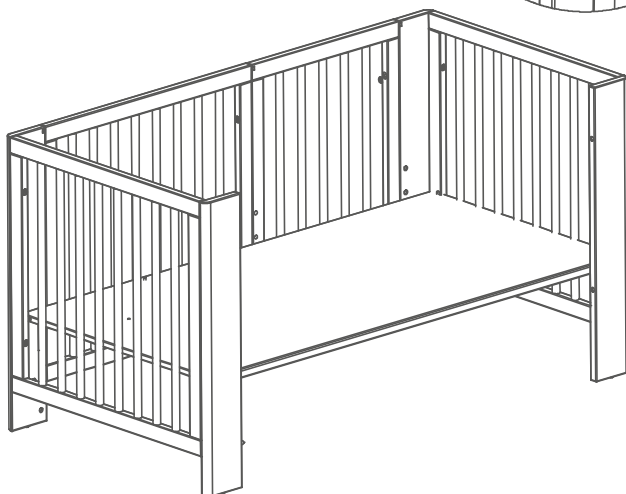

SOFÁ JUNIOR SIN BARRERA
JUNIOR SOFA WITHOUT BARRIER

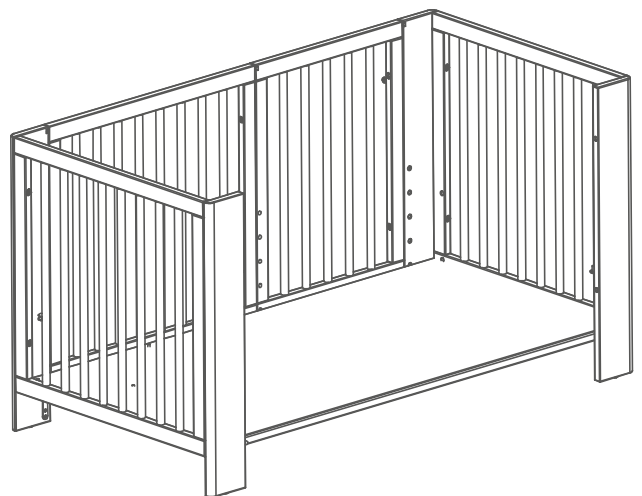

SOFÁ MONTESSORI SIN BARRERA
MONTESSORI SOFA WITHOUT BARRIER

OK!!!

EXTRACCIÓN LATERAL MÓVIL
MOBILE SIDE EXTRACTION

CAMA JUNIOR
JUNIOR BED

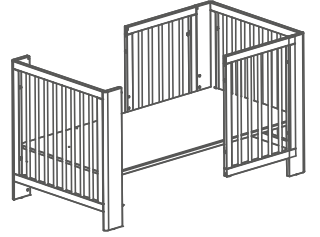

CAMA MONTESSORI
MONTESSORI BED

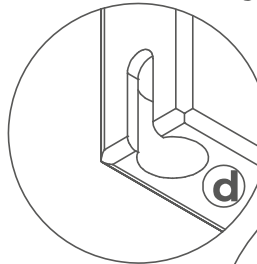
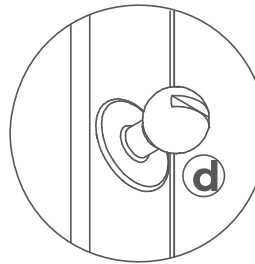
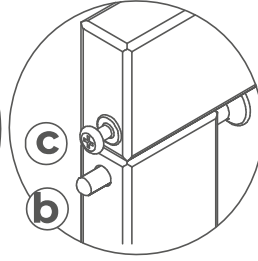
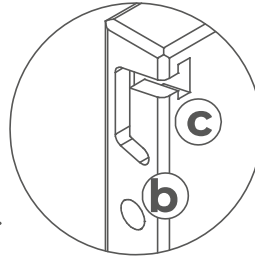
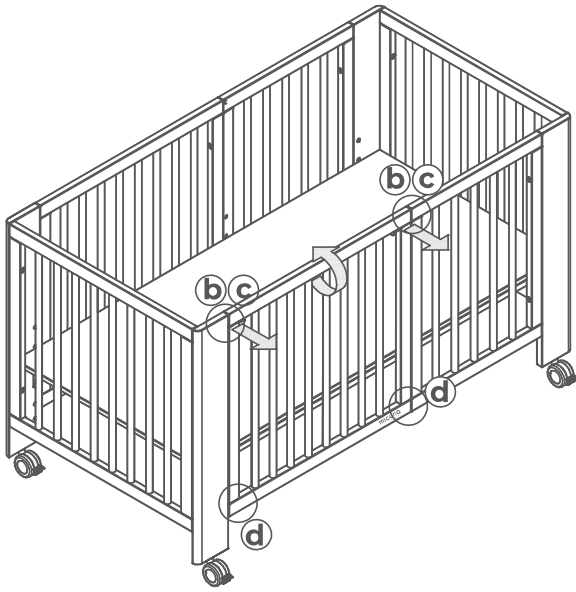
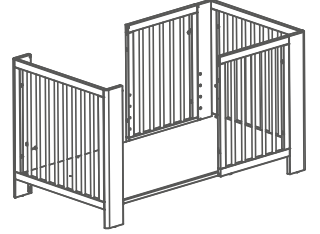

*No guarda mano. Does not keep hand.

1

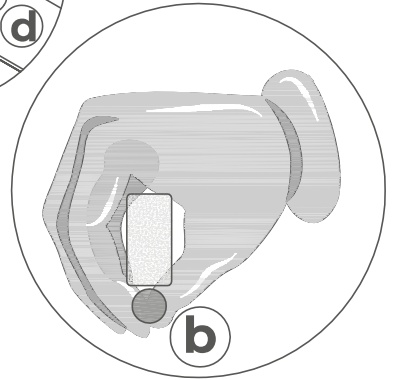
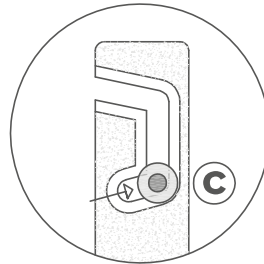
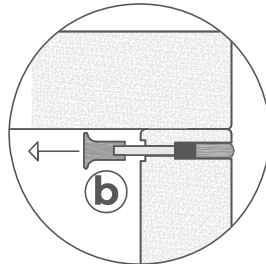
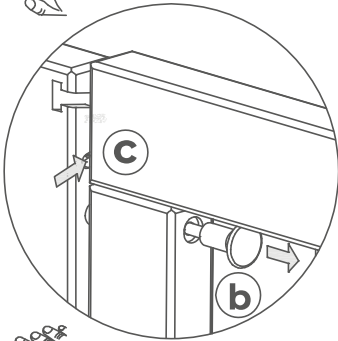

2

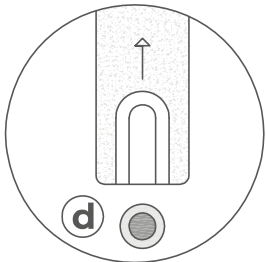
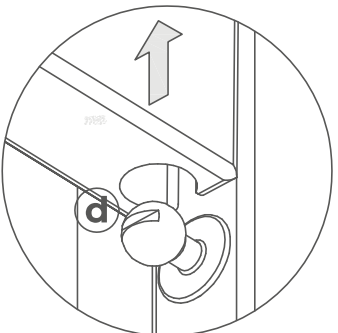
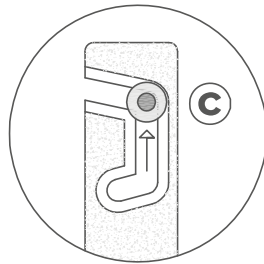
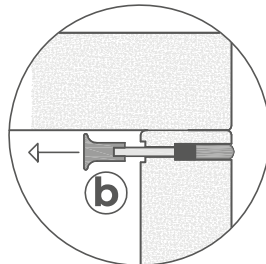
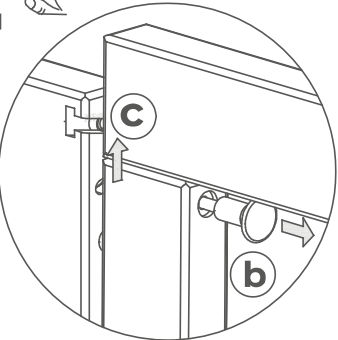

3 

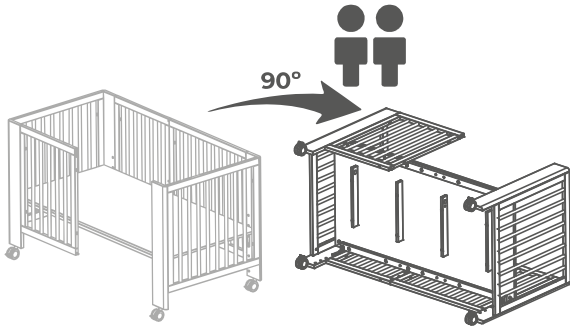
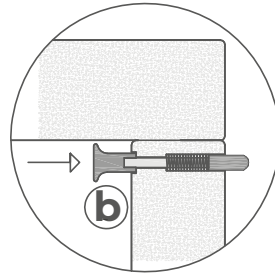
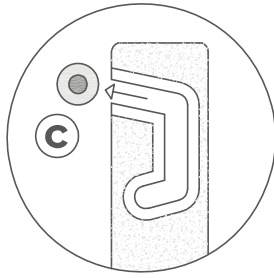
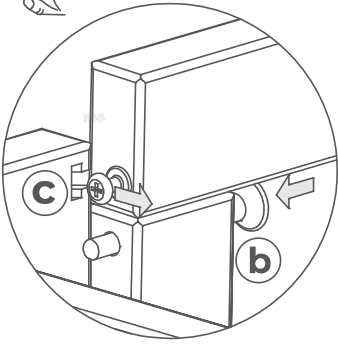

4  ALLEN 4MM

x4

x2

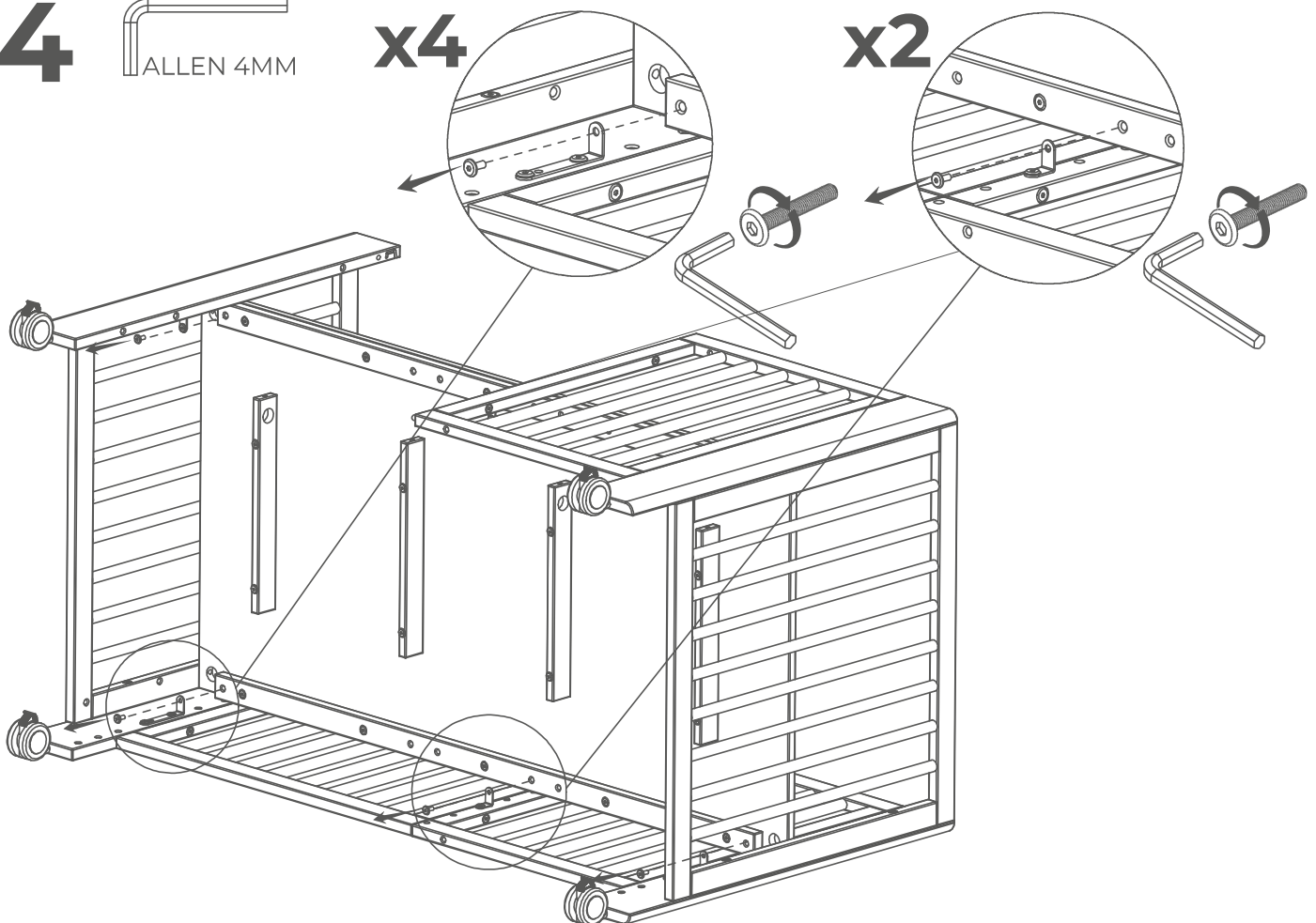

5

ALLEN 4MM X2

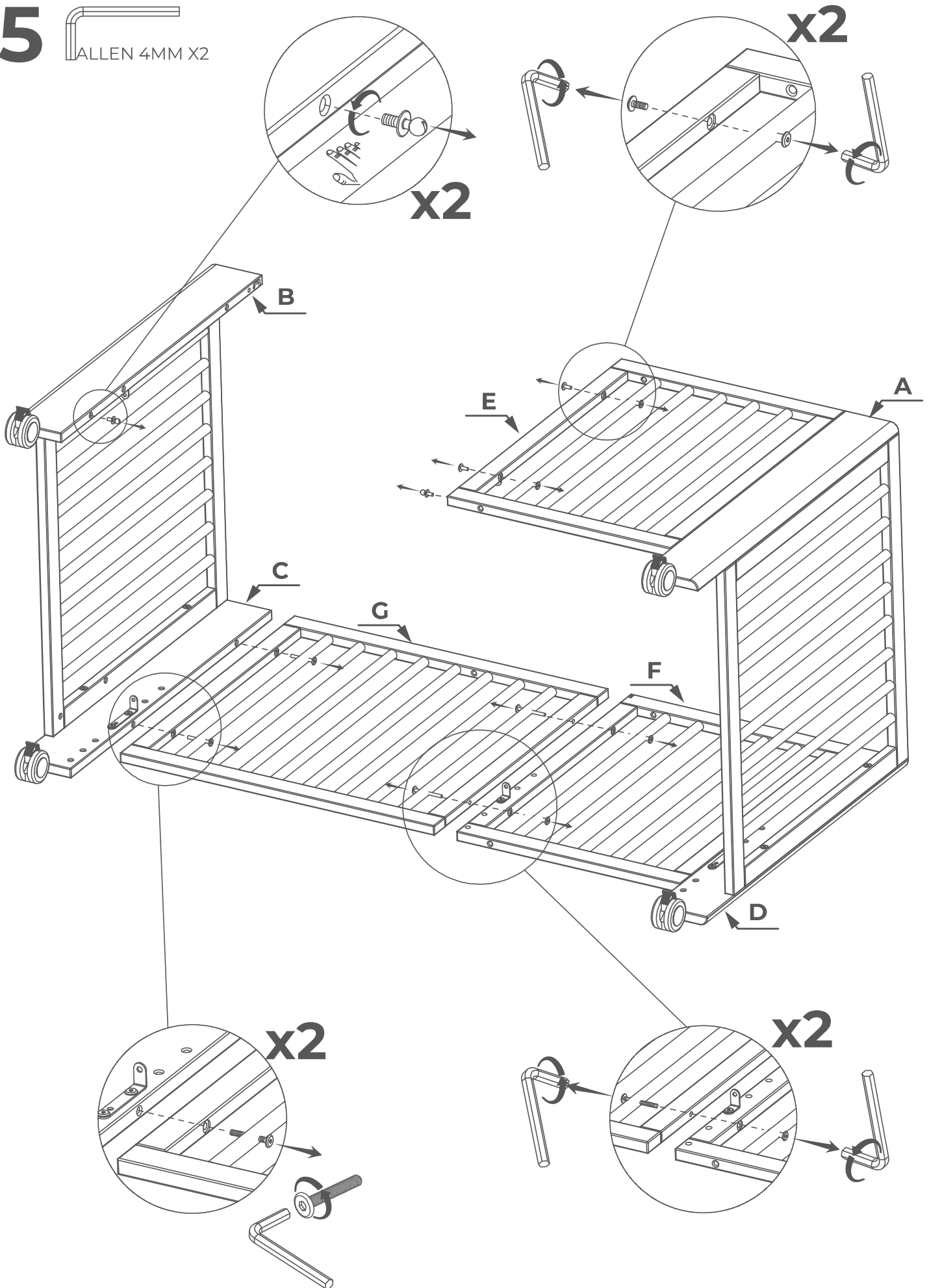

6 ALLEN 4MM



C10313
X4

MEDIDAS CON RUEDAS INCLUIDAS
Desde parte superior del somier al suelo
MEASUREMENTS WITH WHEELS INCLUDED
 From the top of the bed base to the floor

5+4=397mm CAMAJUNIOR
2+1=221mm CAMA MONTESORI
 5+4=397mm JUNIOR BED
 2+1=221mm MONTESORI BED

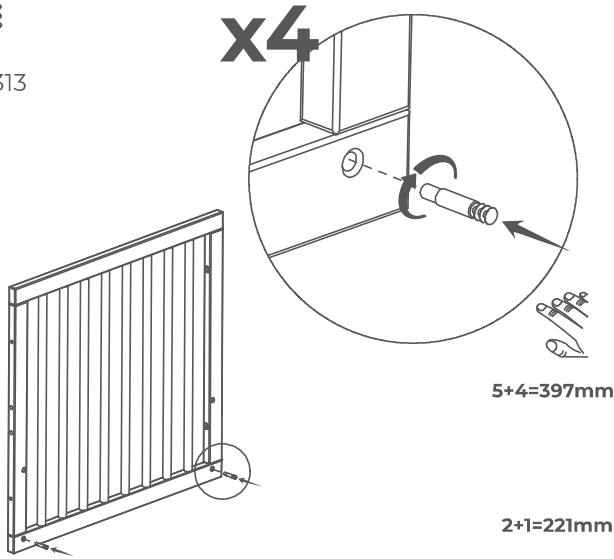

O x2

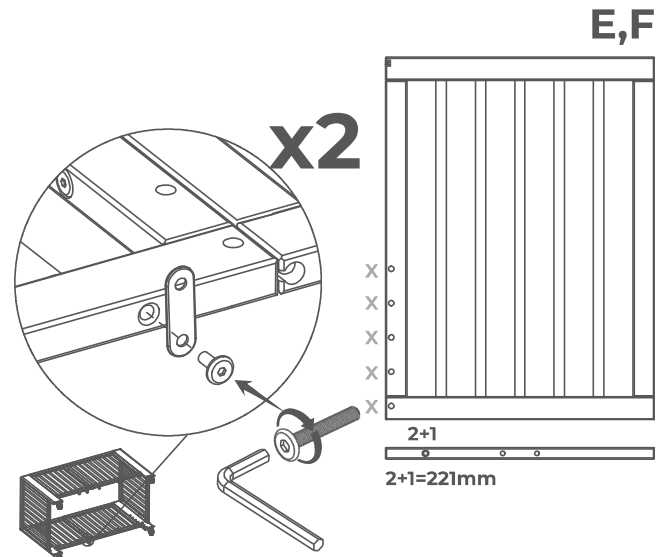
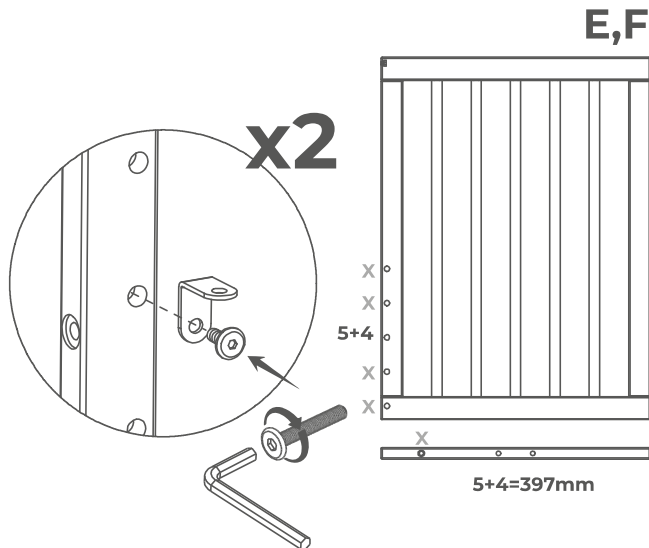
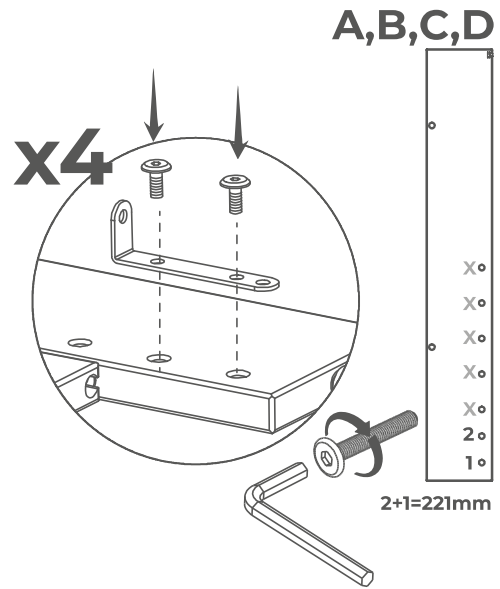
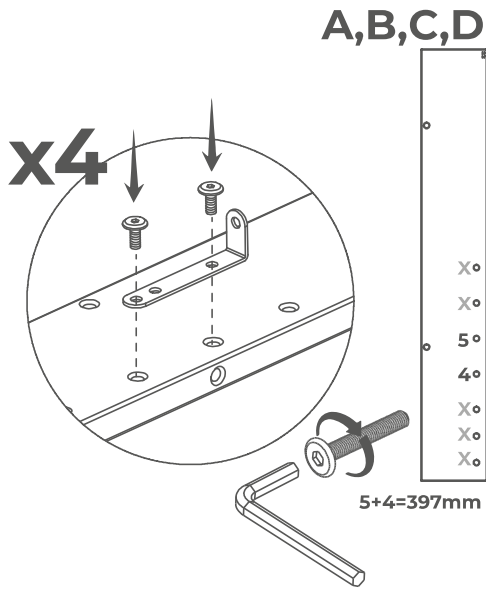
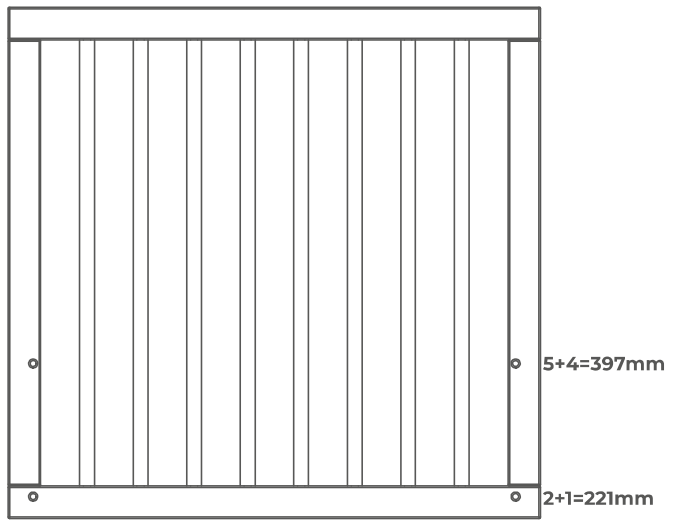

7



C07376
X4

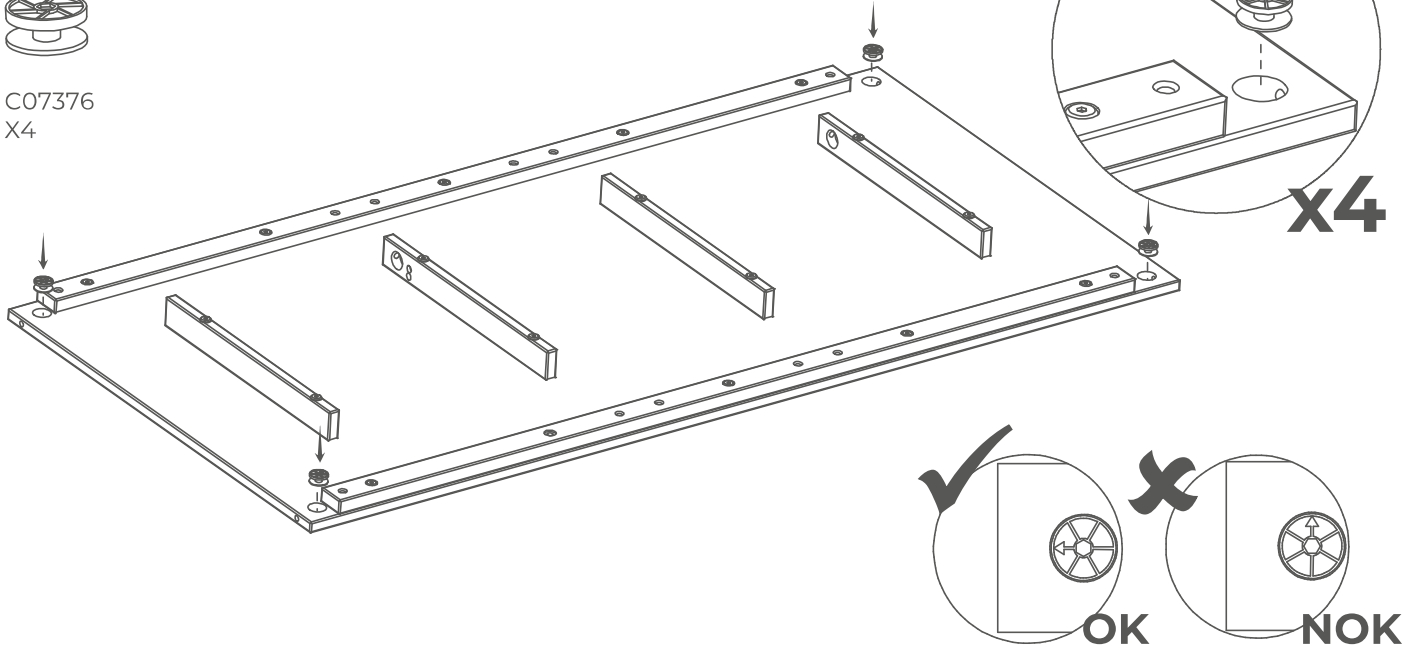

8

ALLEN 5MM

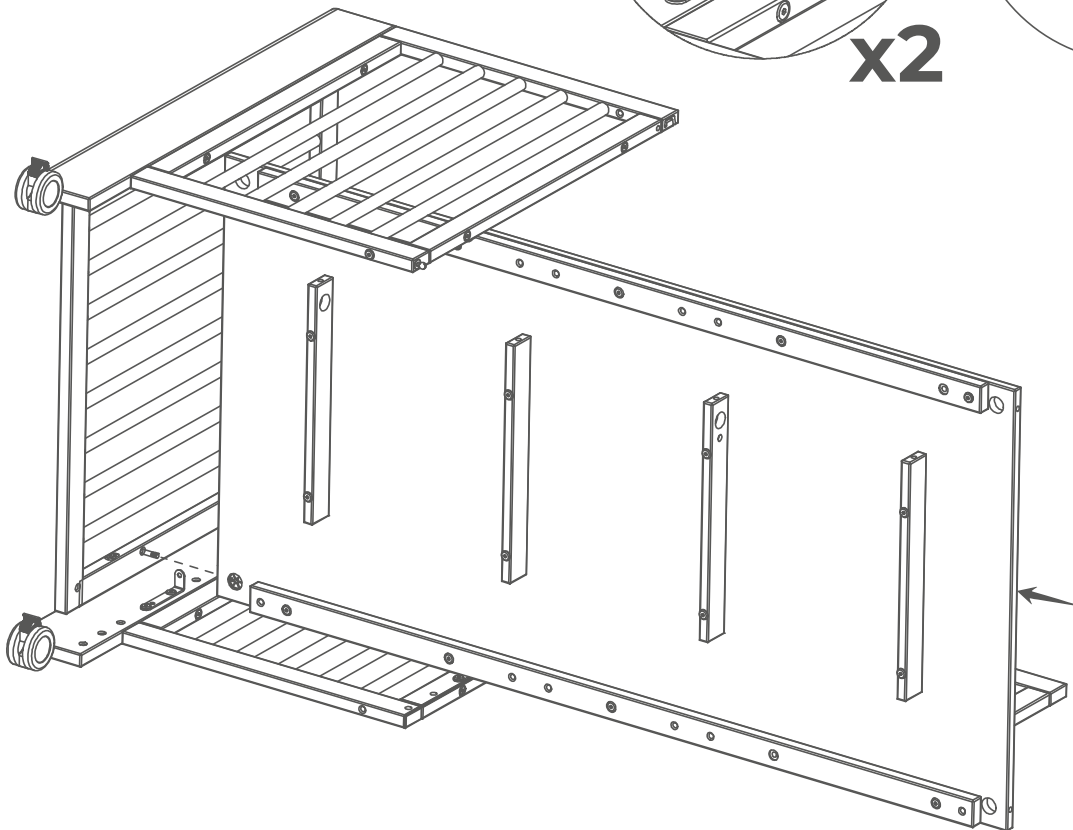
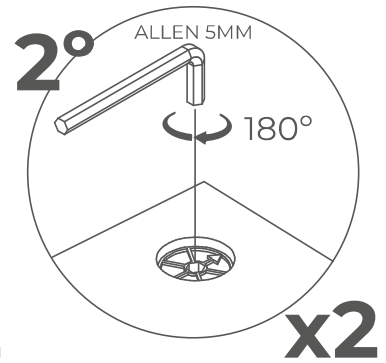
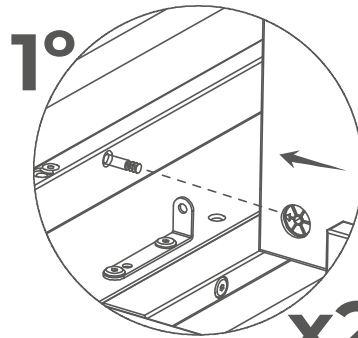

9

ALLEN 5MM

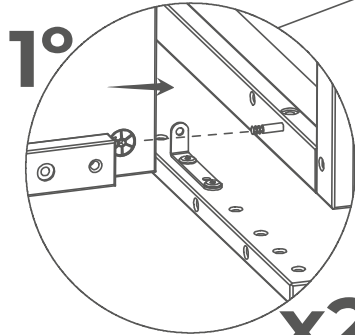
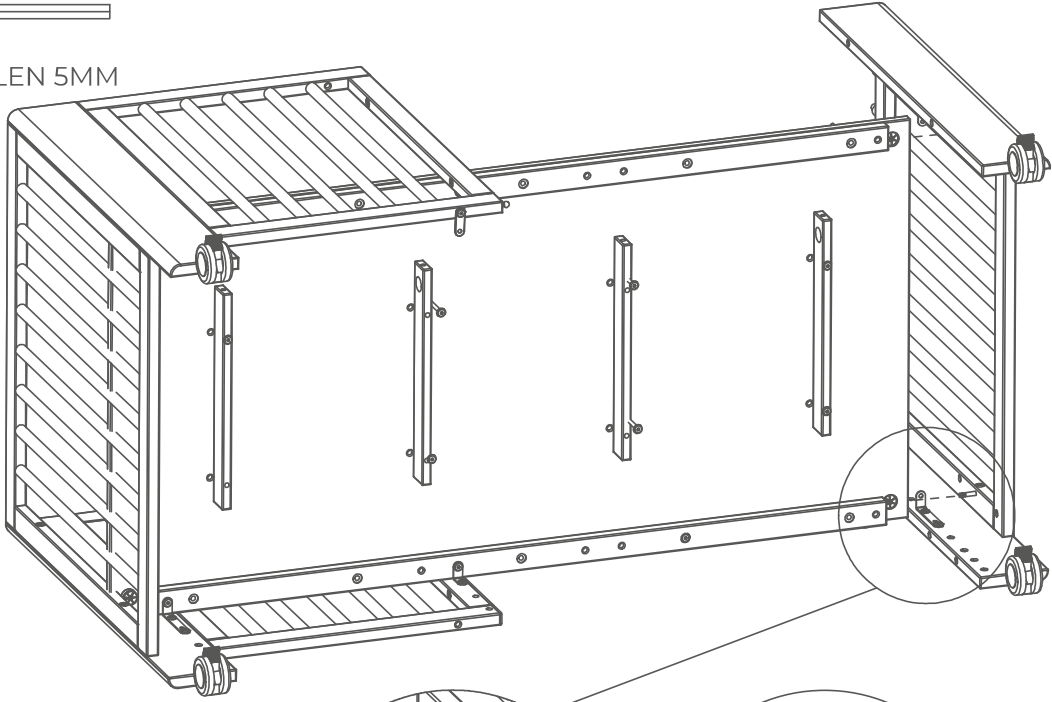

x2

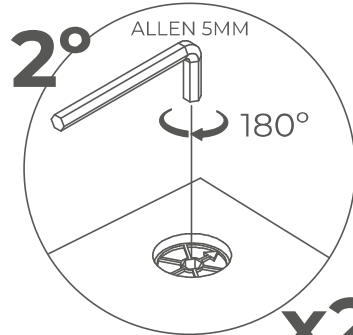

x2

10

ALLEN 4MM



C07915
X6(M6X15)

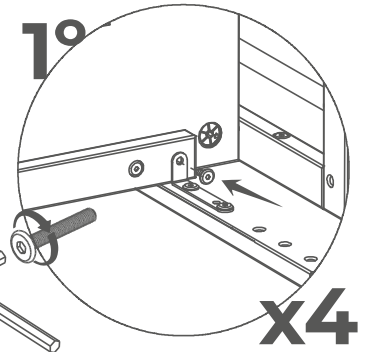
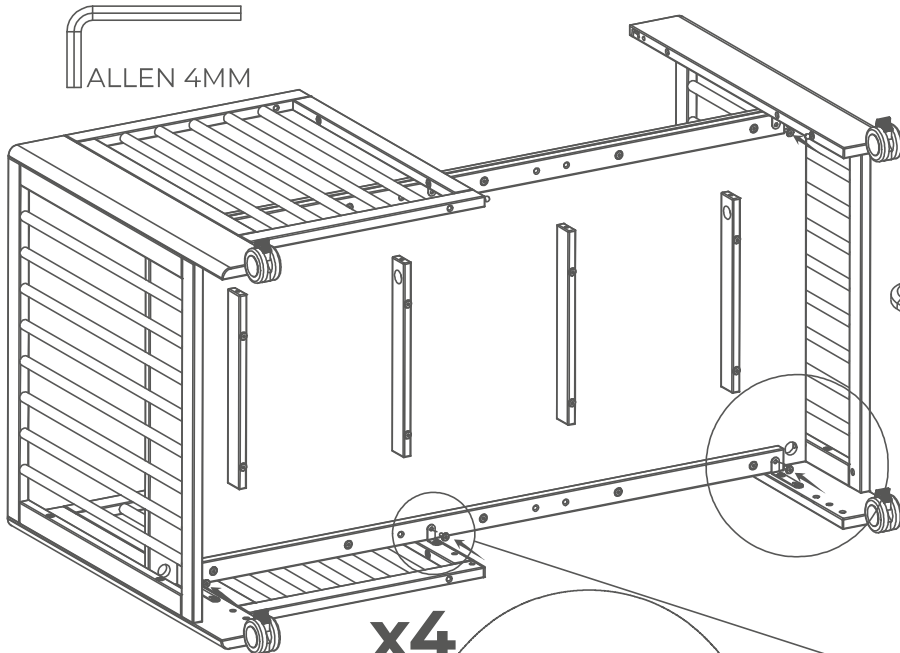

x4

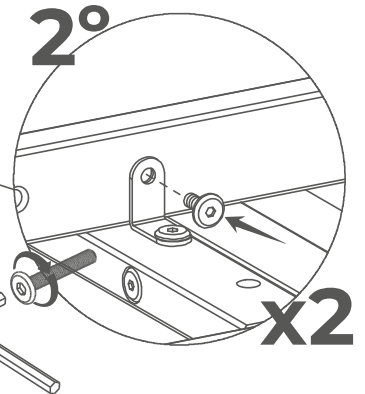
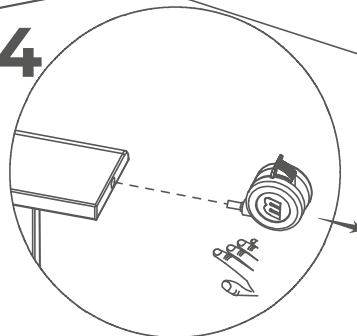

x2

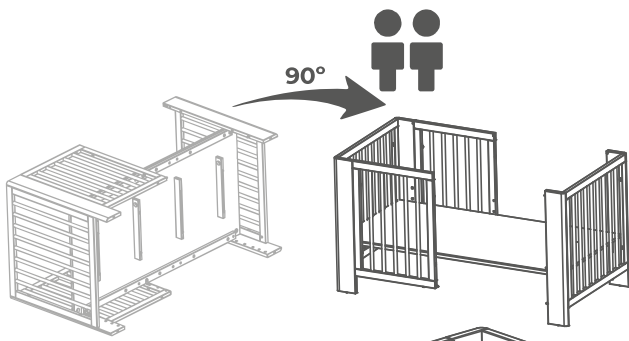

CAMA JUNIOR DOS BARRERAS
 JUNIOR BED TWO BARRIERS

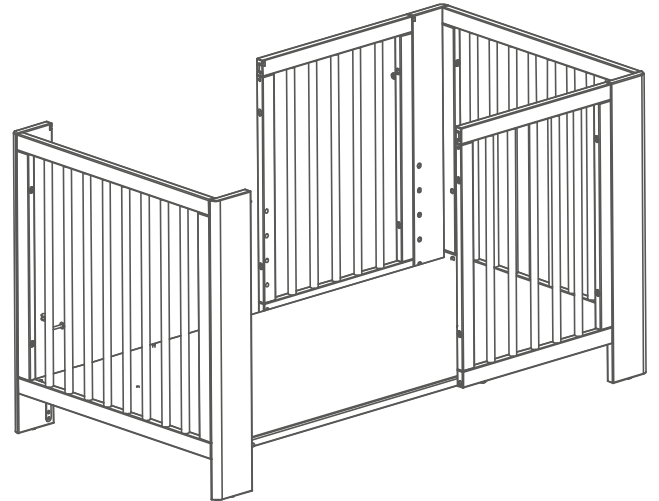

CAMA MONTESSORI DOS BARRERAS
 MONTESSORI BED TWO BARRIERS

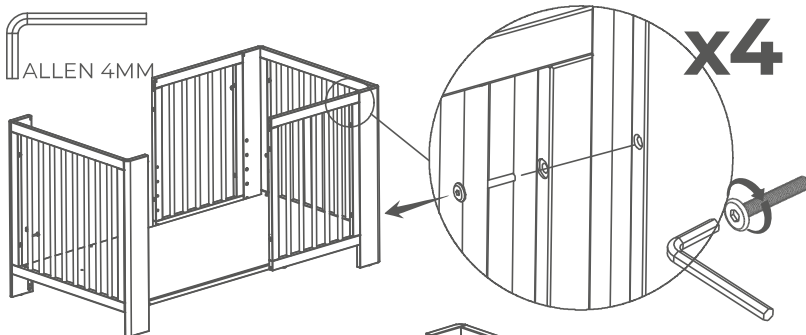

OK!!!

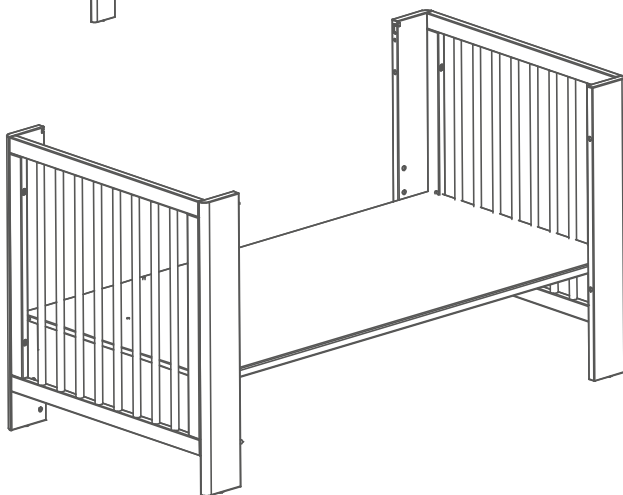

CAMA JUNIOR SIN BARRERAS
 JUNIOR BED WITHOUT BARRIERS

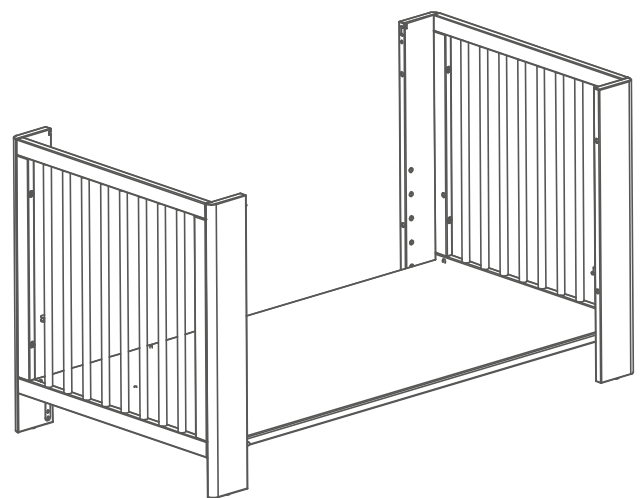

CAMA MONTESSORI SIN BARRERAS
 MONTESSORI BED WITHOUT BARRIERS

OK!!!

EXTRACCIÓN LATERAL MÓVIL
MOBILE SIDE EXTRACTION

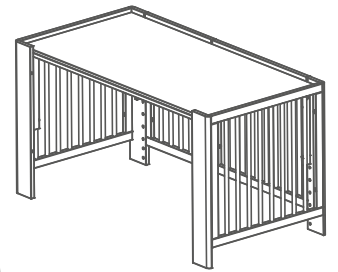

ESCRITORIO
DESK

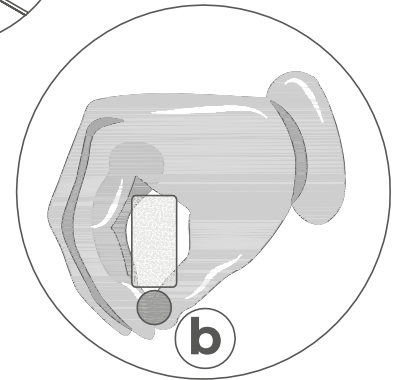
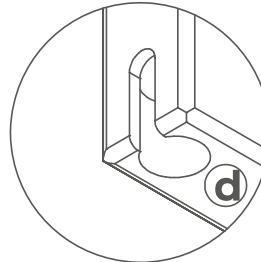
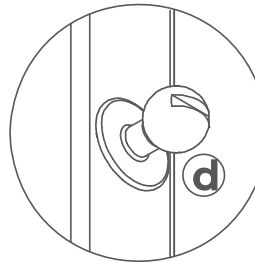
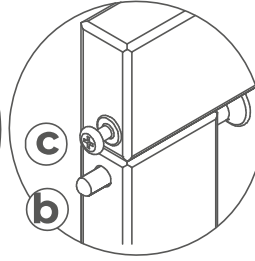
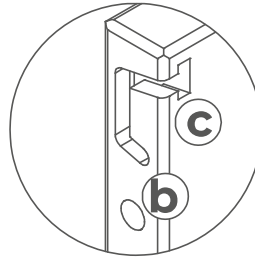
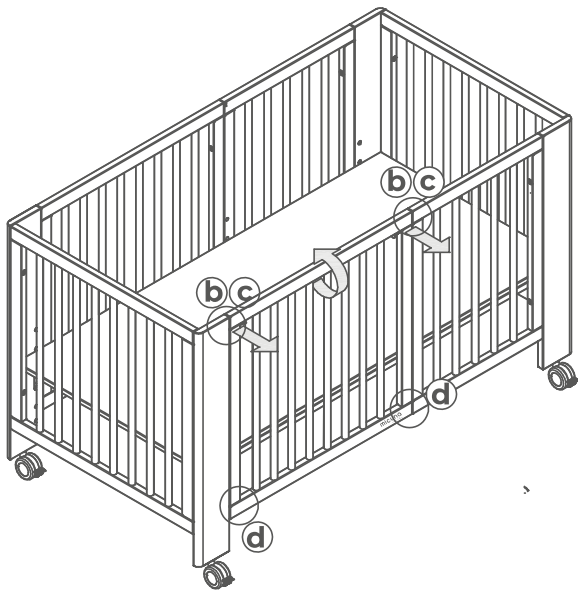

1

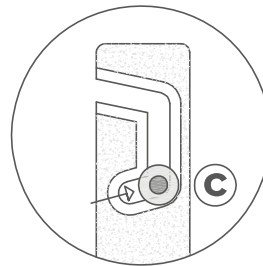
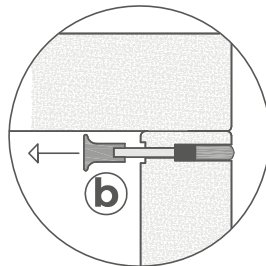
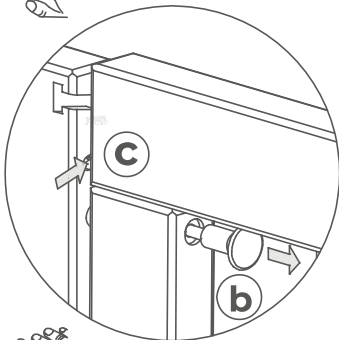

2

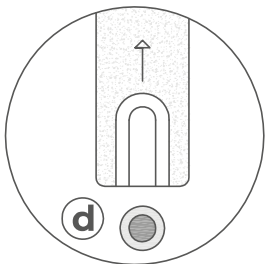
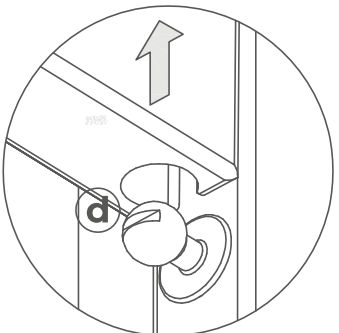
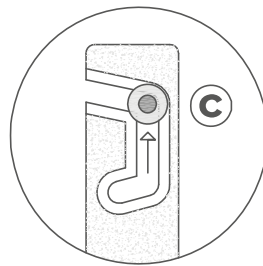
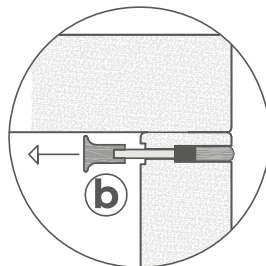
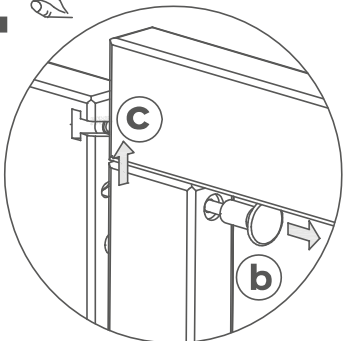

3

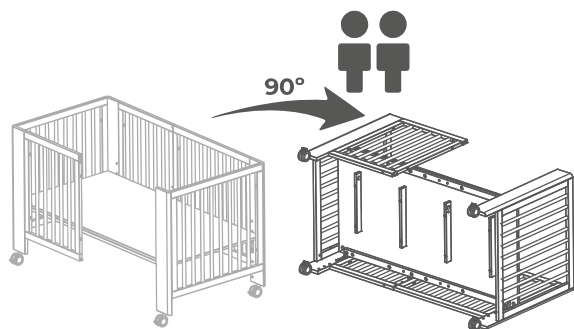
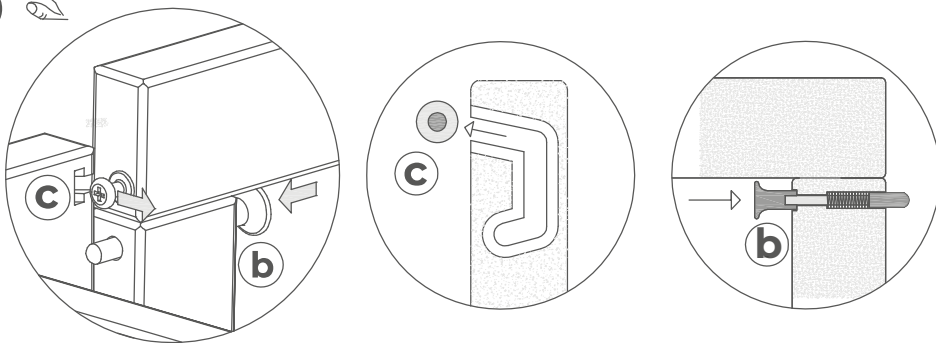

4

ALLEN 4MM

1°

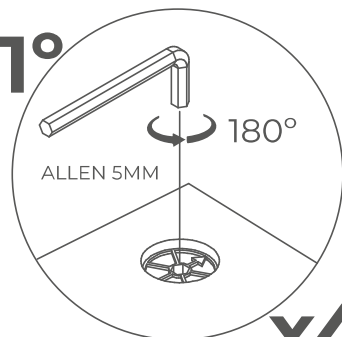

x4

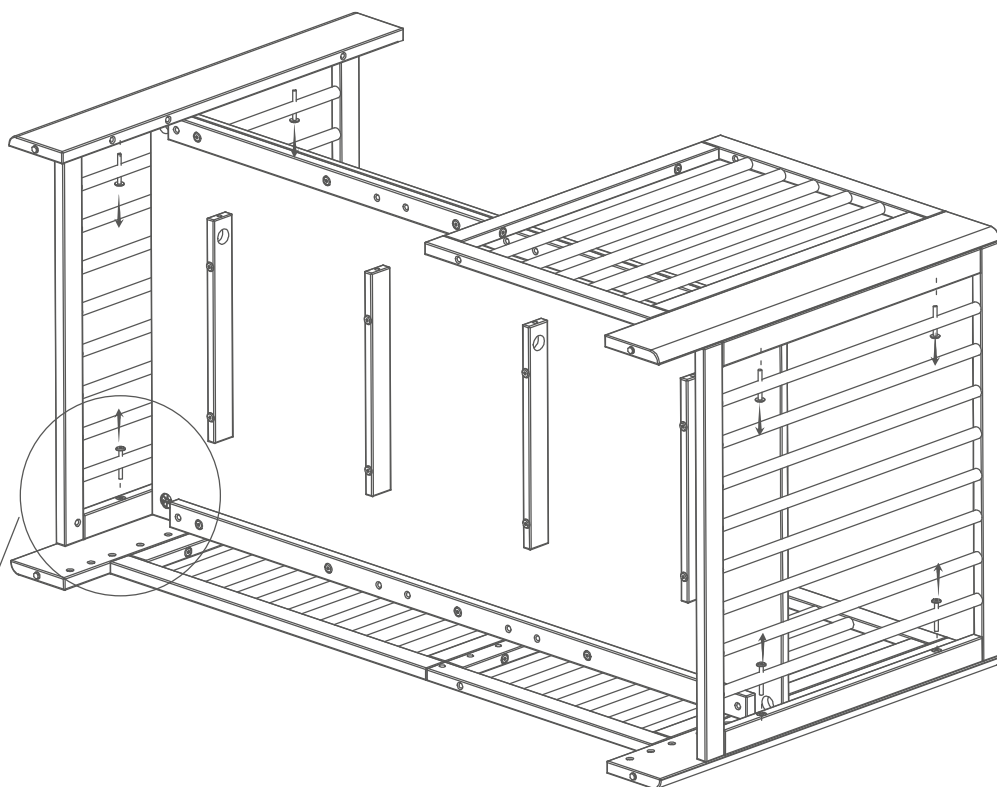
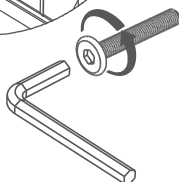
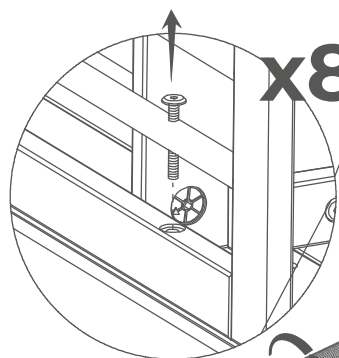

5

ALLEN 4MM

A,B,C,D

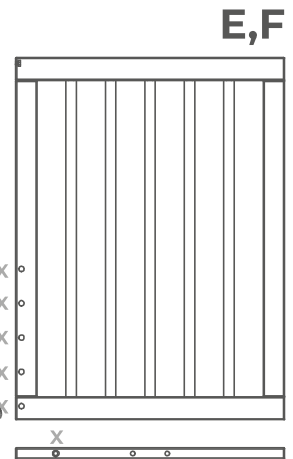
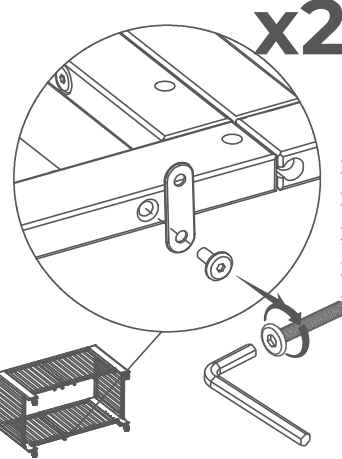
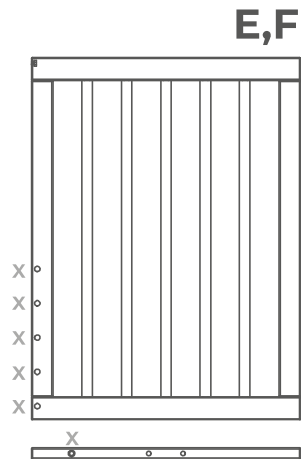
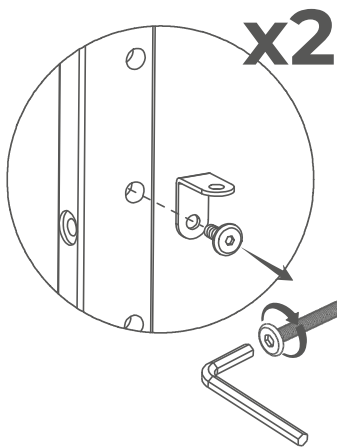
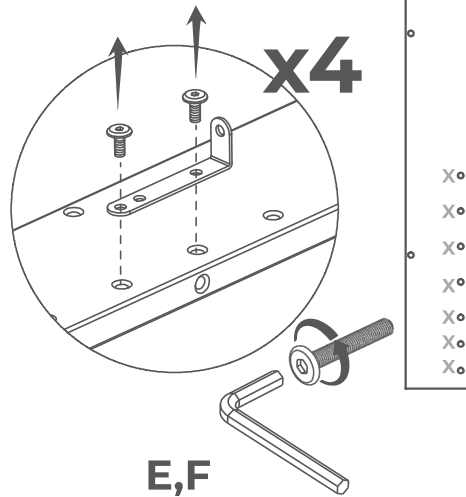

6

ALLEN 4MM

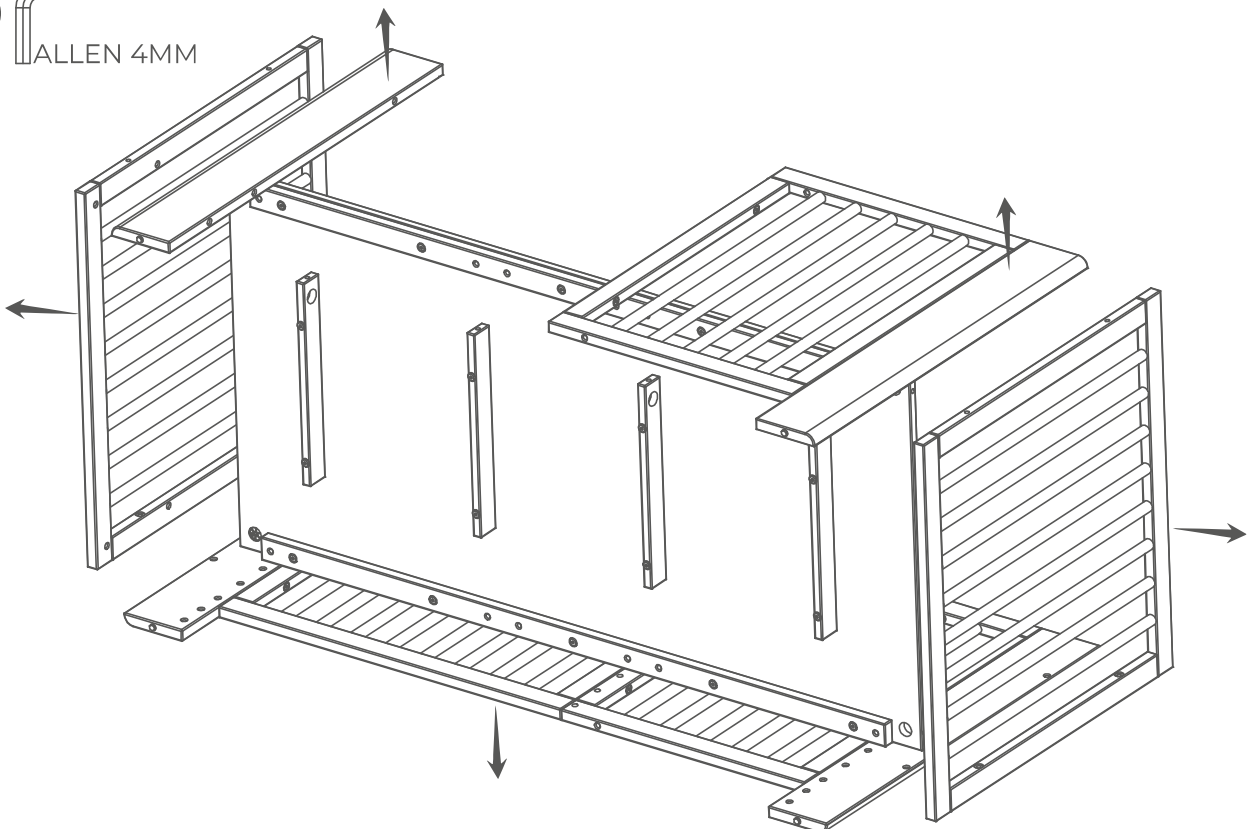

7



ALLEN 4MM

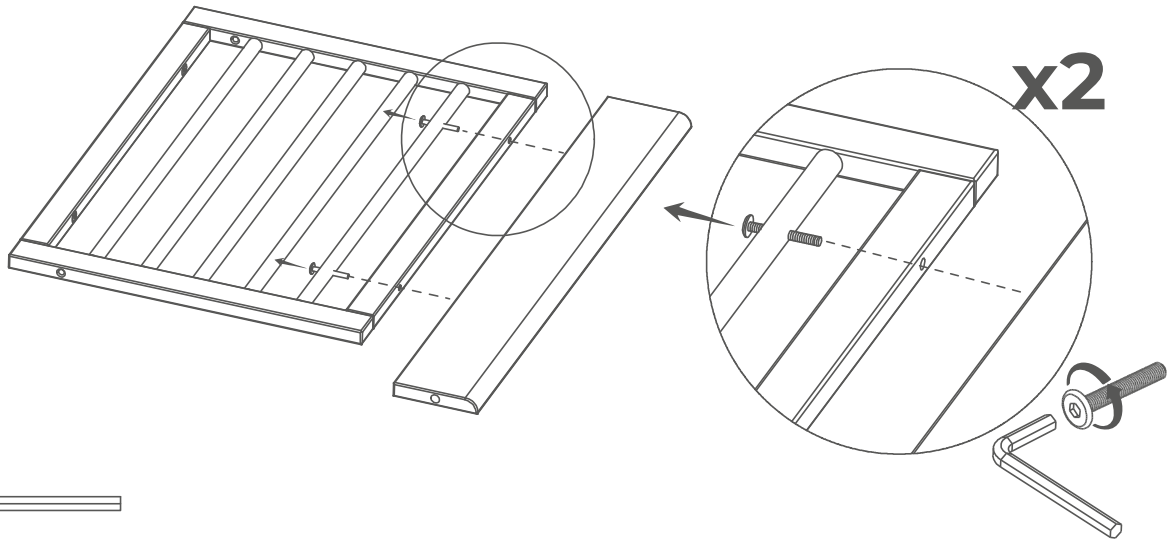

8



ALLEN 4MM

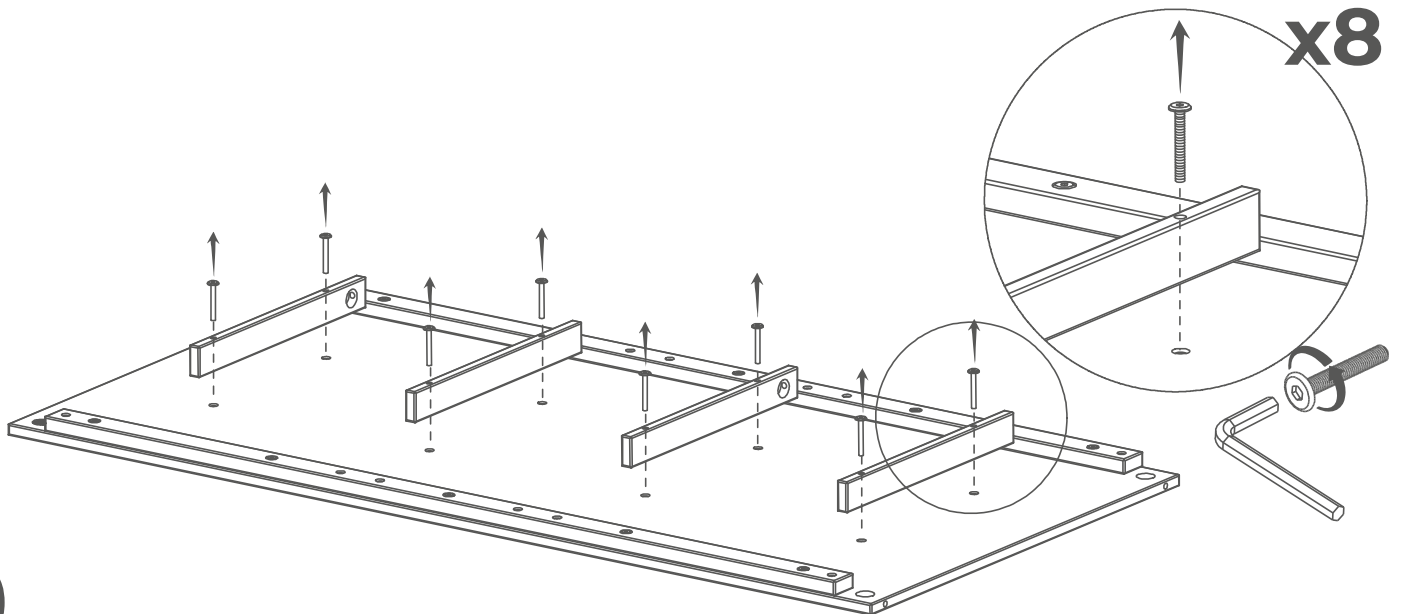

9



C10313
X4

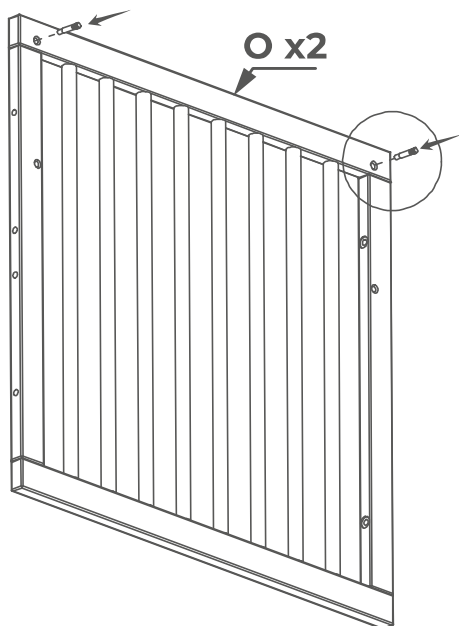

MEDIDAS SIN RUEDAS
Desde parte superior del TABLERO al suelo
MEASUREMENTS WITHOUT WHEELS
From top of BOARD to ground

759mm

10

ALLEN 4MM

C06545
X4 (M6X50)

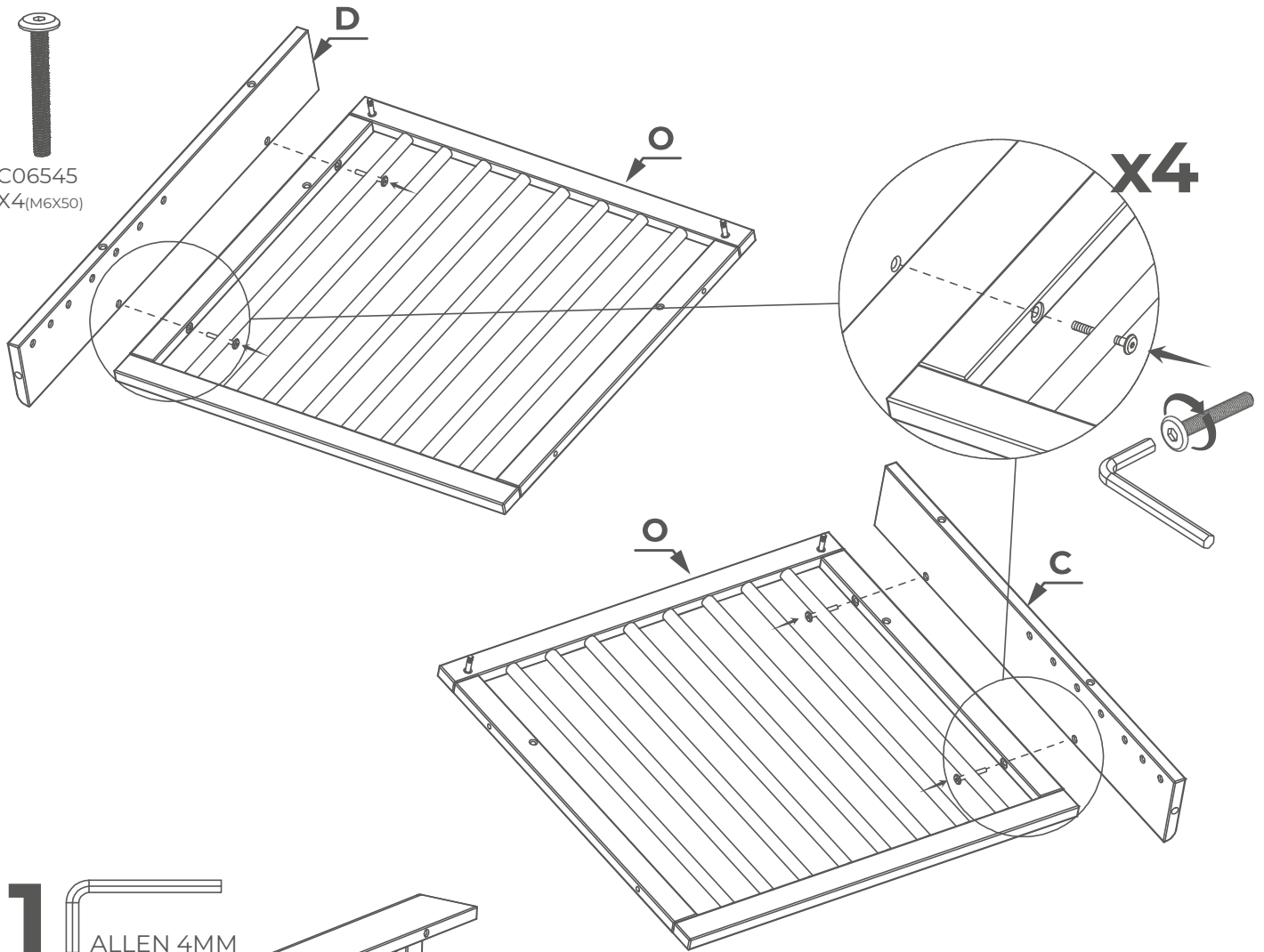

11

ALLEN 4MM

C06545
X2 (M6X50)

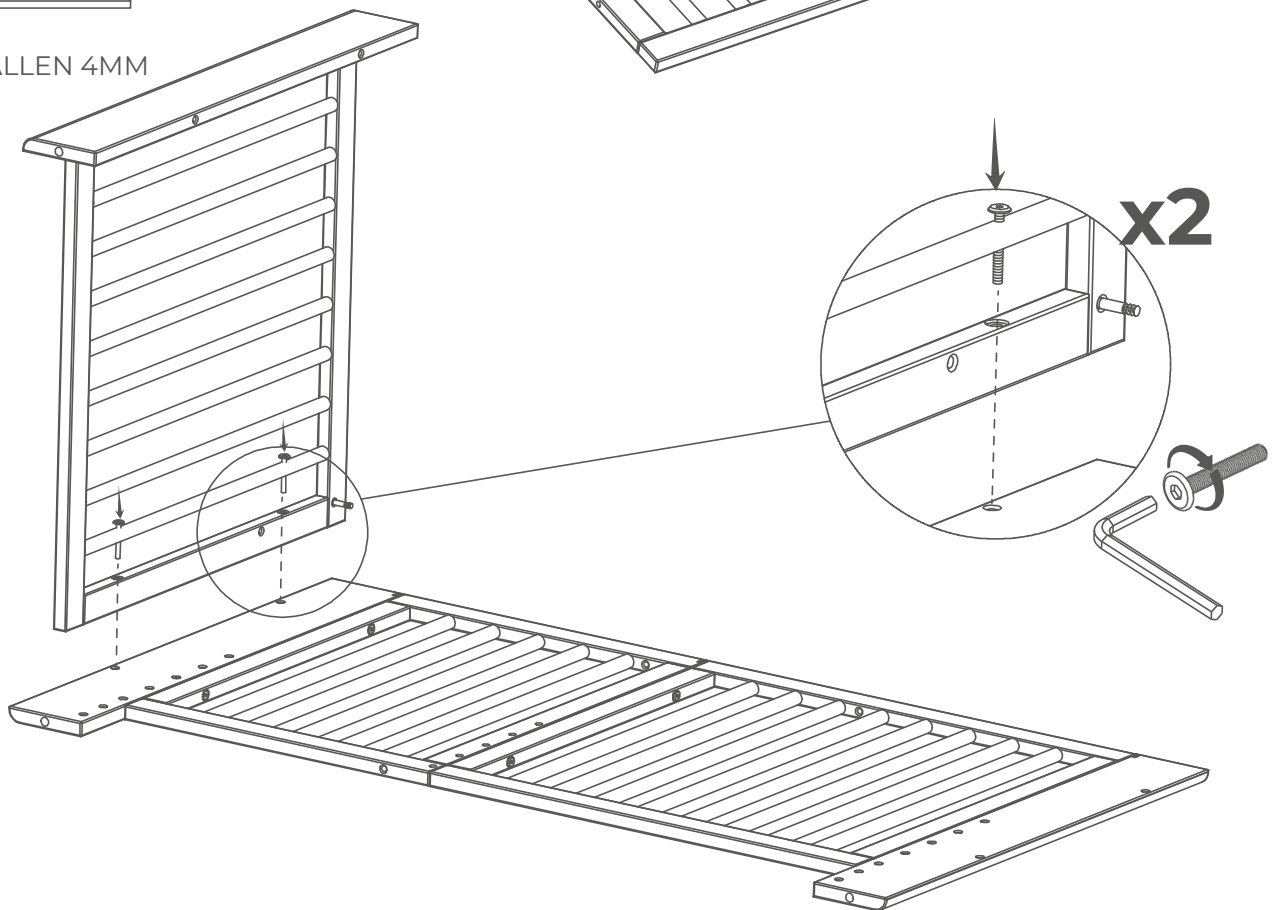

12



C07376
X4

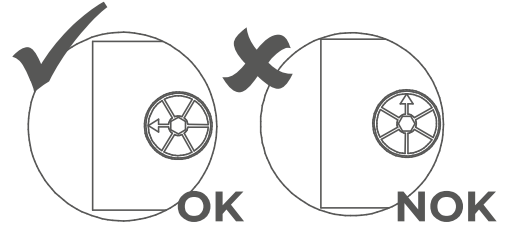
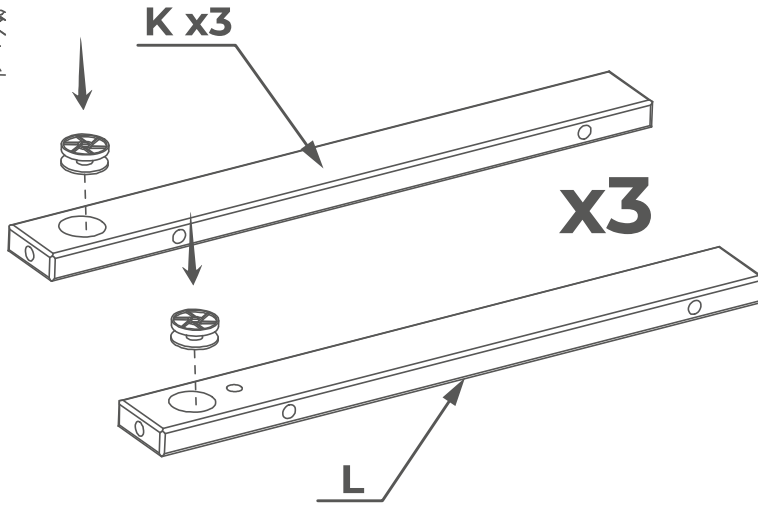

13



C10313
X4

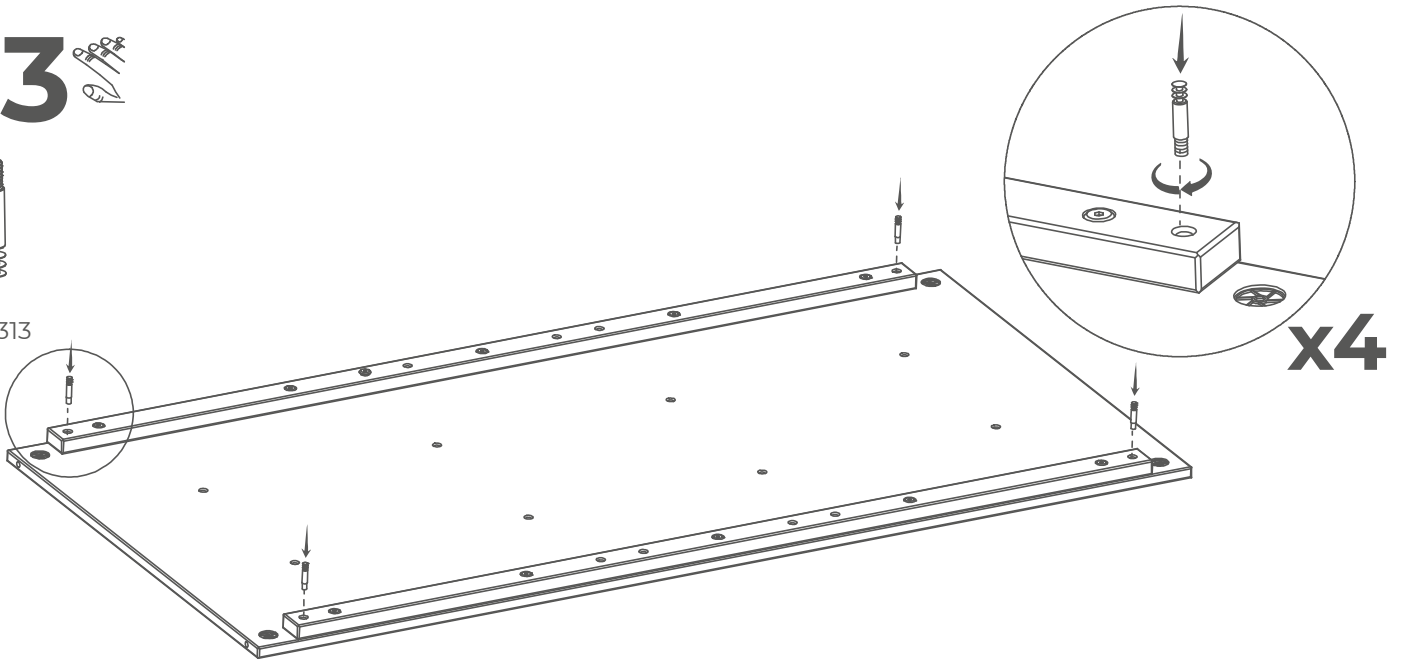

14



1°

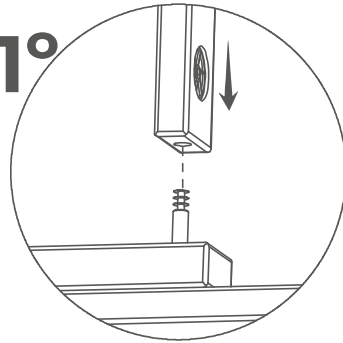

2°

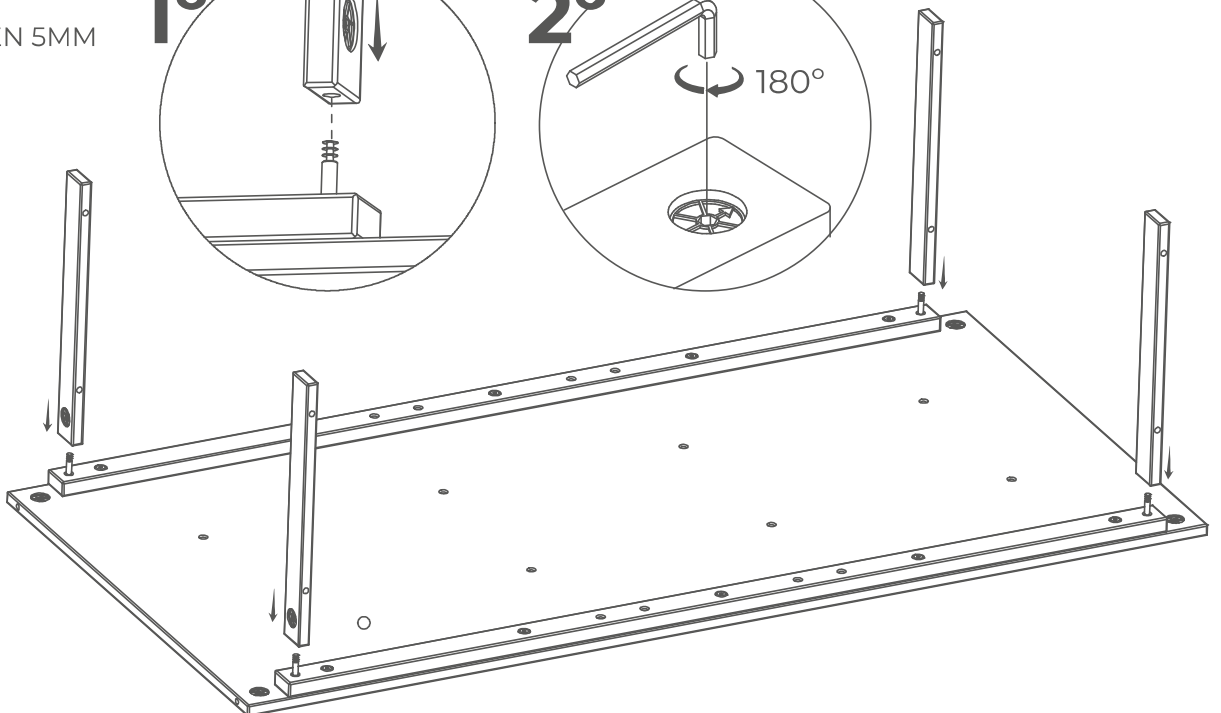
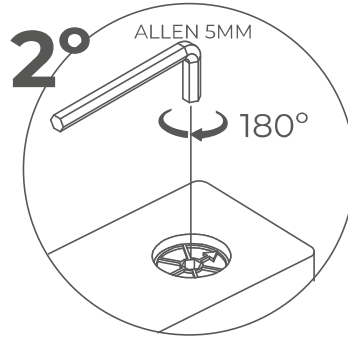

15

ALLEN 5MM

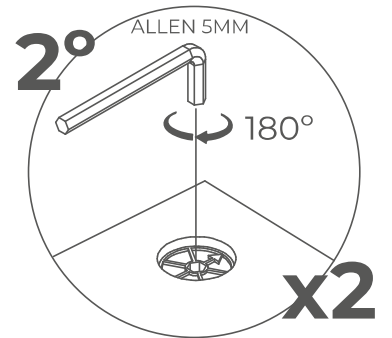
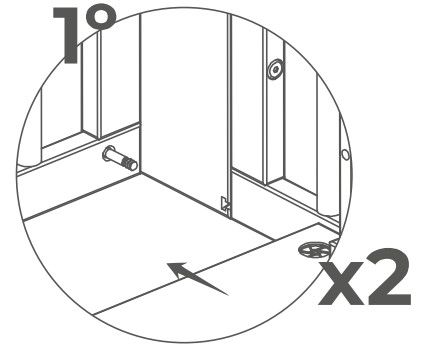
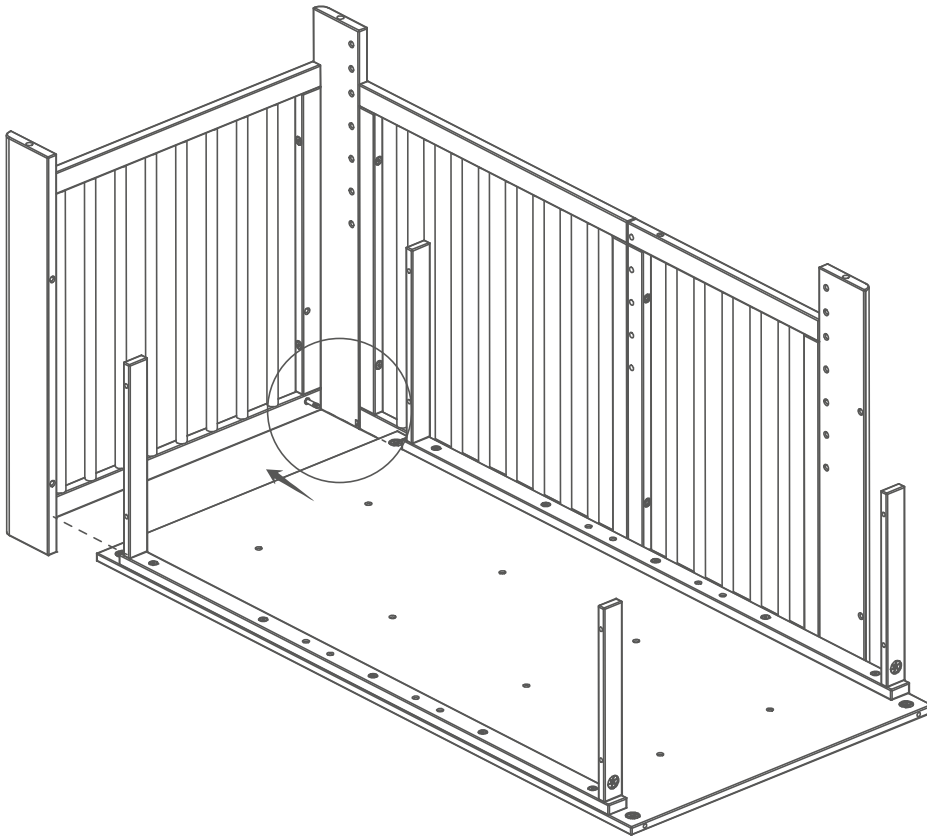

16

ALLEN 5MM

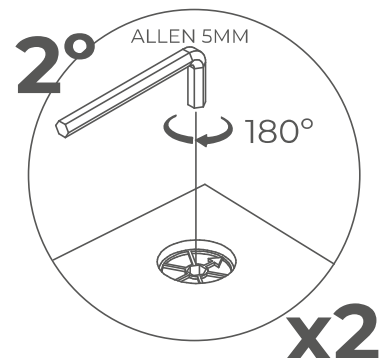
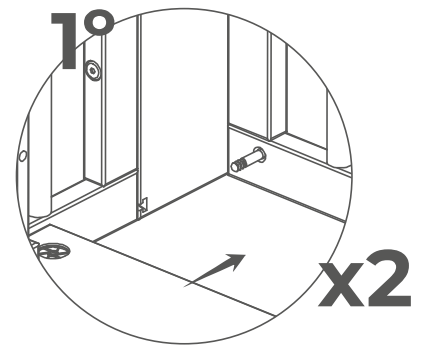
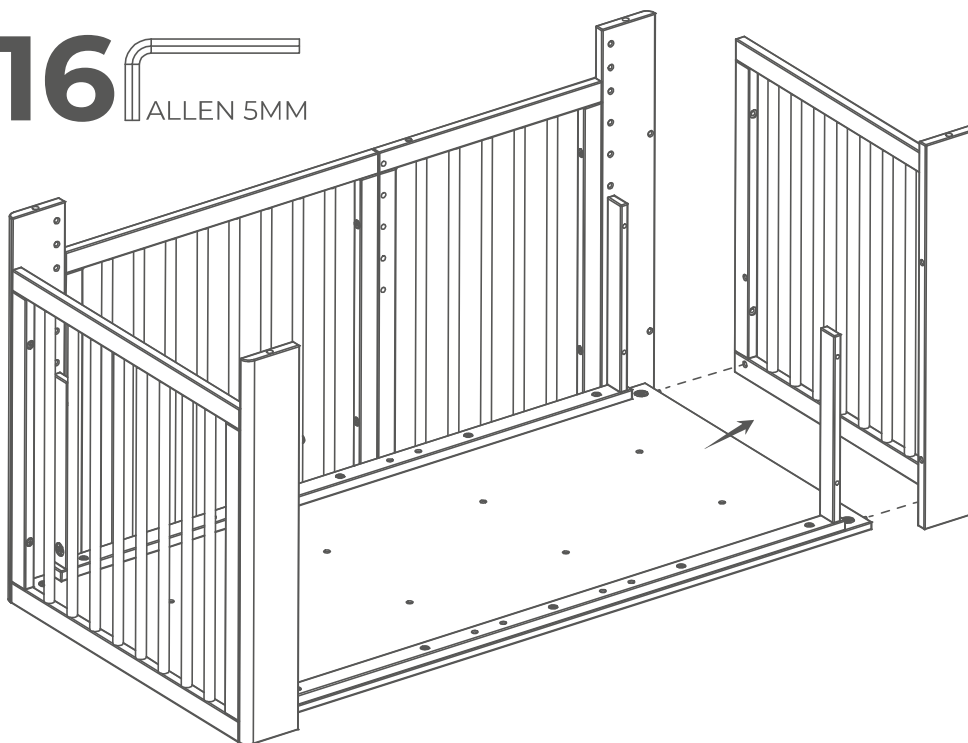

17

ALLEN 4MM

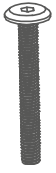

C06545
X6 (M6x50)

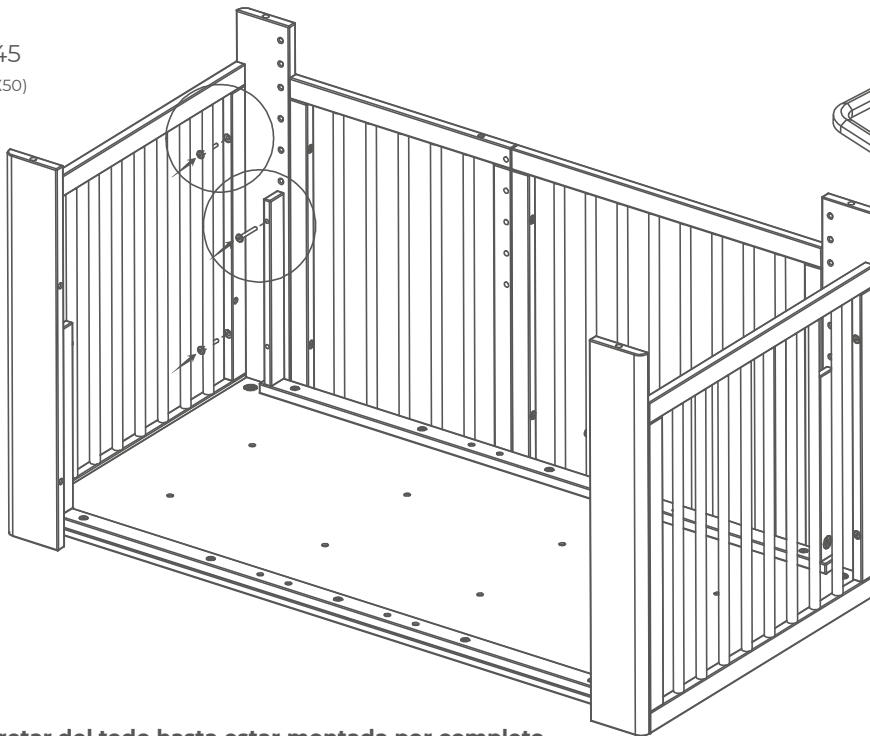

***No apretar del todo hasta estar montada por completo**
*Do not tighten completely until fully assembled

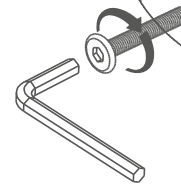
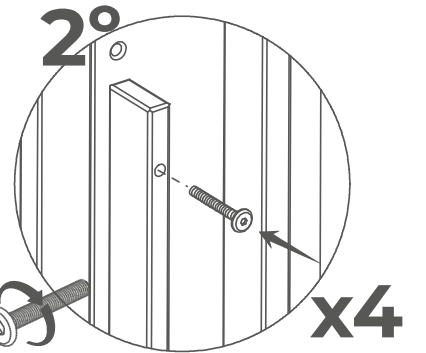
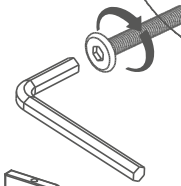
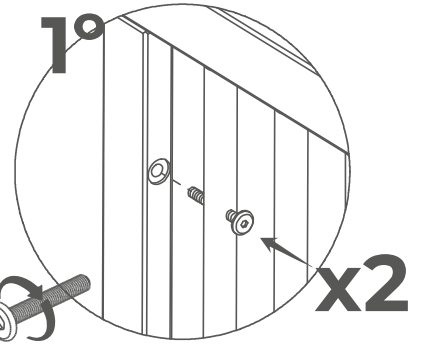

18

ALLEN 5MM



C07915
X2 (M6x15)



C08300
X2 (M6x30)



C14647
X2

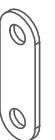

C15246
X2

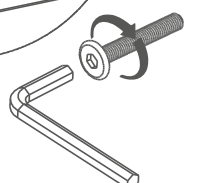
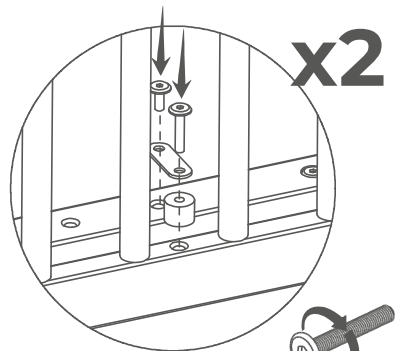
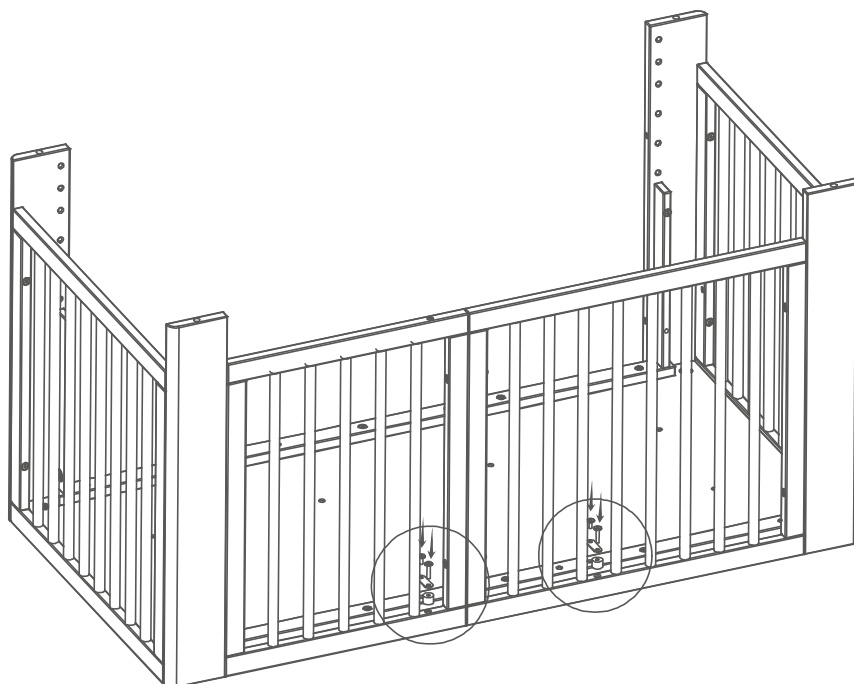

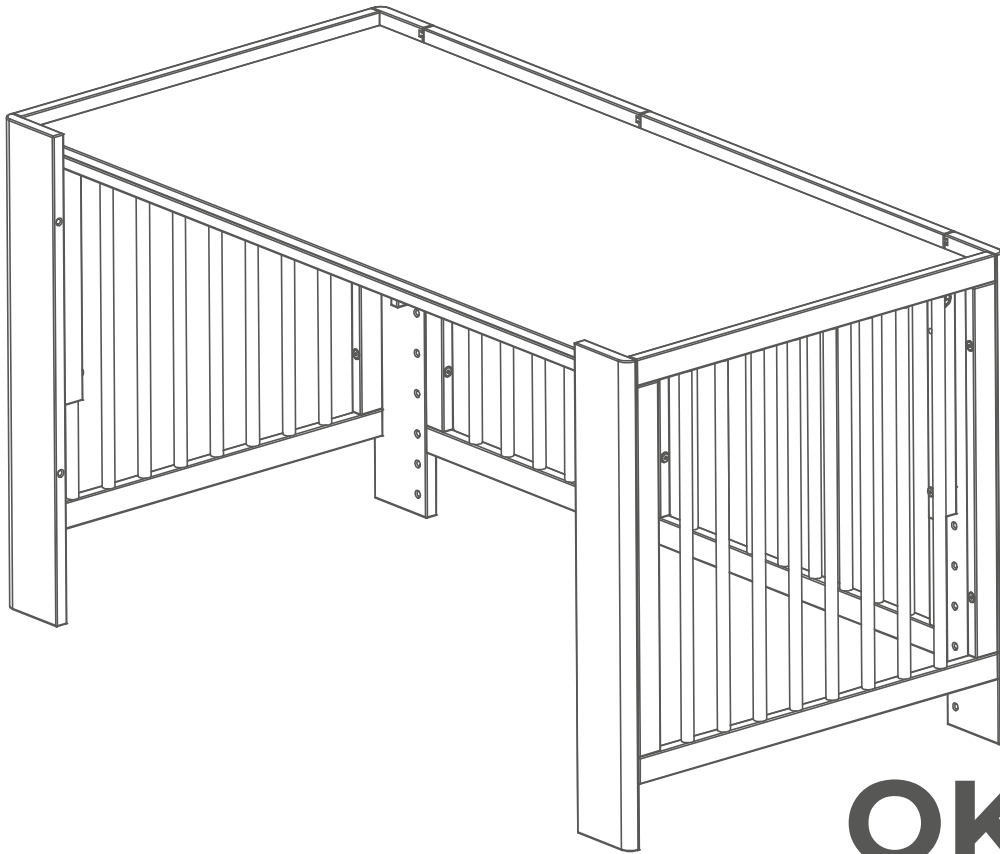
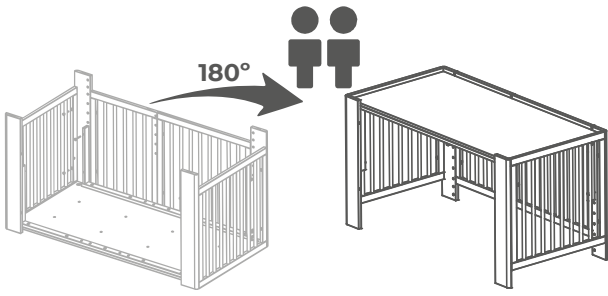

OK!!!

• ES •

- 1: **Advertencia:** Tener presente el riesgo de situar la cuna cerca del fuego o de otras fuentes de calor, tales como aparatos de calefacción eléctricos, de calefacción a gas, etc.
- 2: **Advertencia:** No utilizar la cuna si cualquiera de sus componentes está roto, deteriorado o falta, y utilizar únicamente piezas de repuesto aprobadas por el fabricante.
- 3: **Advertencia:** No dejar ningún objeto en la cuna ni situar esta cerca de otro producto, que pudiera proporcionar un punto de apoyo para el pie del niño, o presentar riesgo de asfixia o de estrangulamiento, por ejemplo, cuerdas, cordones de cortinas o persianas, etc.
- 4: **Advertencia:** No utilizar más de un colchón en la cuna.
- 5: La cuna está lista para su uso únicamente cuando los mecanismos de bloqueo están en funcionamiento. El funcionamiento debe comprobarse cuidadosamente antes de utilizar la cuna.
- 6: La posición más baja es la más segura, lo más conveniente es utilizar siempre esta posición desde el momento en que el niño sea capaz de sentarse.
- 7: El espesor del colchón elegido debe ser tal que la altura interna (es decir, la distancia entre la superficie del colchón y la parte superior de la estructura de la cuna) sea al menos de 500 mm con el somier en la posición más baja, y al menos 200 mm con el somier en la posición más alta.
- 8: El tamaño mínimo del colchón a utilizar en la minicuna big será de entre 88 cm de largo y 68 cm de ancho y en la cuna entre 138 cm de largo y 68 cm de ancho. La longitud y anchura debe ser tal que el hueco entre el colchón y los laterales y los cabeceros, no debe ser mayor de 30 mm
- 9: Para su limpieza utilizar un paño suave humedecido.
- 10: Para prevenir riesgos de caídas cuando del niño sea capaz de salir de la cuna, la cuna no debe utilizarse más para ese niño.
- 11: Todos los dispositivos del montaje deben estar siempre convenientemente ajustados y los tornillos no deben estar sueltos, pues el niño podría pincharse o engancharse con la ropa o accesorios (cordones, collares, cadenas para chupetes de bebé, etc...), lo que supondría un peligro de estrangulación.
- 12: Los dispositivos de montaje deberían estar siempre convenientemente ajustados, y deben verificarse periódicamente y, si es necesario reajustarse.
- 13: NO APRIETE LOS TORNILLOS DEL TODO HASTA TENERLA COMPLETAMENTE MONTADA.

• EN •

1. WARNING: Be aware of the risk of open fire and other sources of strong heat, such as electric bar fires, gas, fires in the near of the cot.
2. WARNING: Do not use the cot if any part of it is broken, torn or missing and use only spare parts by the manufacturer.
3. Do not leave anything in the cot or place near the cot any product, which could provide a foothold or present a danger of suffocation or strangulation, e.g. strings, blind/curtain cords, etc.
4. WARNING: do not use more than one mattress in the cot.
5. Statement that a cot is ready for use only when the locking mechanisms are engaged and check carefully that they are fully engaged before first use.
6. If the height of the cot-base is adjustable, a statement that the lowest position is the safest and that the base should always be used in that position when the baby is old enough to sit up.
7. Thickness of the mattress shall be such that the internal height (surface of the mattress to the upper edge of the cot frame) is at least 500 mm in the lowest position of the cot base and at least 200mm in the highest position of the cot base.
- 8: The minimum size of the mattress to be used in the big mini crib will be between 88 cm long and 68 cm wide and in the crib between 138 cm long and 68 cm wide. The length and width must be such that the gap between the mattress and the sides and headboards must not be greater than 30 mm.
9. Cleaning instructions: For cleaning please use a wet and smooth cloth
10. Statement to prevent injury from falls once the child is able to climb out of the cot, the cot shall no longer be used for that child
11. All assembling devices must always be conveniently adjusted and the screws should not be loose as the child may get hurt or get hooked up with clothes or accessories (laces, necklaces, chains for baby pacifiers, etc ...), which could suppose a danger of strangulation.
12. All assembling devices must always be conveniently adjusted and they must be checked up regularly, readjusting them if necessary.
- 13: DO NOT TIGHTEN THE SCREWS COMPLETELY UNTIL IT HAS BEEN COMPLETELY ASSEMBLED.

• FR •

- 1: Attention: Soyez conscient du lieu où vous situez le lit, dû aux risques de feux provenant de différentes sources de chaleur tels que les appareils de chauffage électriques, de gas, etc...
- 2: Attention: Ne pas utiliser le lit si l'un lui manque un composant, ou bien il est cassé ou endommagé. Et, utiliser uniquement les pièces de rechange du fabricant.
- 3: Attention: Ne jamais laisser un objet dans le lit, ainsi que le situer près d'un autre produit qui pourrait faciliter un point d'appui du pied de l'enfant, ou pourrait présenter un risque d'asphyxie ou d'étranglement, par exemple cordes, lacets, tirettes, etc....
- 4: Attention: Ne pas utiliser plus d'un matelas par lit.
- 5: Le lit est prêt à être utilisé uniquement quand le mécanisme de blocage est en marche. Le fonctionnement doit être vérifié soigneusement avant d'utiliser le lit.
- 6: Quand l'enfant est capable de rester assis, il convient de situer le sommier dans la position la plus basse.
- 7: Pour que l'épaisseur du matelas que vous avez choisi soit le correct, il faudra prendre note de l'information suivante ; Si le sommier du lit se trouve dans la position plus basse, il faut compter au moins 500mm de distance entre la surface du matelas et la partie supérieure de la structure du lit. Si, au contraire le sommier est en position plus haute, la distance requise sera de 200mm.
- 8 : La taille minimale du matelas à utiliser dans le grand mini-berceau sera comprise entre 88 cm de longueur et 68 cm de largeur et dans le berceau entre 138 cm de longueur et 68 cm de largeur. La longueur et la largeur doivent être telles que l'écart entre le matelas et les côtés et têtes de lit ne doit pas dépasser 30 mm.
- 9: Pour son entretien, nettoyer avec un chiffon doux et humidifié.
- 10 : Le lit ne devrait plus être utilisé quand l'enfant est capable de sortir tout seul afin d'éviter les risques de chute.
- 11 : Tous les dispositifs de montage doivent toujours être bien ajustés et les vis ne doivent pas être lâche, puis l'enfant pourrait se piquer ou s'accrocher avec vêtements ou accessoires (des cordons, des colliers, des chaînes de sucettes, etc ...), ce qui supposerait un risque d'étranglement "
- 12 : Tous les dispositifs d'assemblage doivent toujours être bien ajustés et contrôlés régulièrement, et les réajuster si c'est nécessaire.
- 13 : NE SERREZ PAS COMPLÈTEMENT LES VIS AVANT QU'ELLES SONT COMPLÈTEMENT ASSEMBLÉES.

• IT •

- 1: AVVERTENCIA. Non collocare la culla vicino a fuoco o qualsiasi fonte di calore, come per esempio stufe elettriche o a gas.
- 2: AVVERTENICA. Non utilizzare la culla nel caso in cui uno dei pezzi necessari al montaggio siano rotti o mancanti. Utilizzare solamente i pezzi di montaggio approvati dal fabbricante.
- 3: AVVERTENCIA. Non lasciare alcun oggetto nella culla nè posizionare quest'ultimo vicino ad altri oggetti che possano rappresentare un punto d'appoggio per il piede del bambino o che possano provocare soffocamento o asfissia, per esempio corde o cordoni di tende e persiane ecc ecc.
- 4: AVVERTENCIA. Non utilizzare più di un materasso nella stessa culla.
- 5: La è pronta per essere montata solamente quando gli ingranaggi del bloccaggio sono in funzione. Il funzionamento deve essere attentamente verificato prima di usare la culla.
- 6: Collocare il materasso nella posizione più bassa rappresenta la opzione più sicura e conveniente. Si consiglia di utilizzare questa opzione a partire dal momento in cui il neonato è in grado di stare seduto.
- 7: Lo spessore del materasso scelto deve essere tale che l'altezza interna (ossia, la distanza tra la superficie del materasso e la parte superiore della struttura della culla) sia per lo meno di 500 mm collocando il somier nella posizione più bassa o per lo meno 200 mm se si colloca il somier nella posizione più alta.
- 8: La dimensione minima del materasso da utilizzare nella culla mini grande sarà compresa tra 88 cm di lunghezza e 68 cm di larghezza e nella culla tra 138 cm di lunghezza e 68 cm di larghezza. La lunghezza e la larghezza devono essere tali che lo spazio tra il materasso e le sponde e le testiere non deve essere superiore a 30 mm.
- 9: PULIZIA. Per la pulizia della culla si consiglia di utilizzare un panno morbido inumidito.
- 10: Per prevenire rischi quando il neonato è in grado di uscire dalla culla, quest'ultima non dovrà utilizzarsi più.
- 11: Tutti i dispositivi di montaggio devono essere accuratamente aggiustati e i vite non devono essere sciolti, perché il bambino potrebbe bucarsi o agganciarsi con i vestiti o accessori (micelici, collane, catene per ciucci, etc...).
- 12: Tutti i dispositivi di montaggio devono sempre essere regolate correttamente, e devono essere controllati regolarmente, e riaggiustare-li se fosse necessario.
- 13: NON SERRARE COMPLETAMENTE LE VITI FINO A CHE NON È STATO COMPLETAMENTE MONTATO.

micuna
made with love



FORMATO DIGITAL
DIGITAL FORMAT