

Instrucciones de montaje · Assembly Instructions

## B-1971 MARTHA

**ES** • IMPORTANTE: A CONSERVAR PARA FUTURAS CONSULTAS. LÉASE ATENTAMENTE.

**EN** • IMPORTANT: PLEASE KEEP FOR FUTURE REFERENCE. READ CAREFULLY.

**FR** • ATTENTION: CONSERVER POUR CONSULTER AU FUTUR.

**IT** • IMPORTANTE: LEGGERE ATTENTAMENTE LE ISTRUZIONE. TENERE PER FUTURE CONSULTAZIONE.

**PT** • IMPORTANTE: MANTENHA PARA FUTURAS CONSULTAS. LÉASE ANENTAMENTE.

**R** • ВАЖНО: СОХРАНИТЕ ДЛЯ ДАЛЬНЕЙШЕГО ИСПОЛЬЗОВАНИЯ. ВНИМАТЕЛЬНО ПРОЧИТИТЕ.

**A** • — لامعتسالا لببق اديج أرفا. ةعج ارم لل ظفح ا. ماه

**CN** • 重要事项：保留以备将来参考，请仔细阅读。

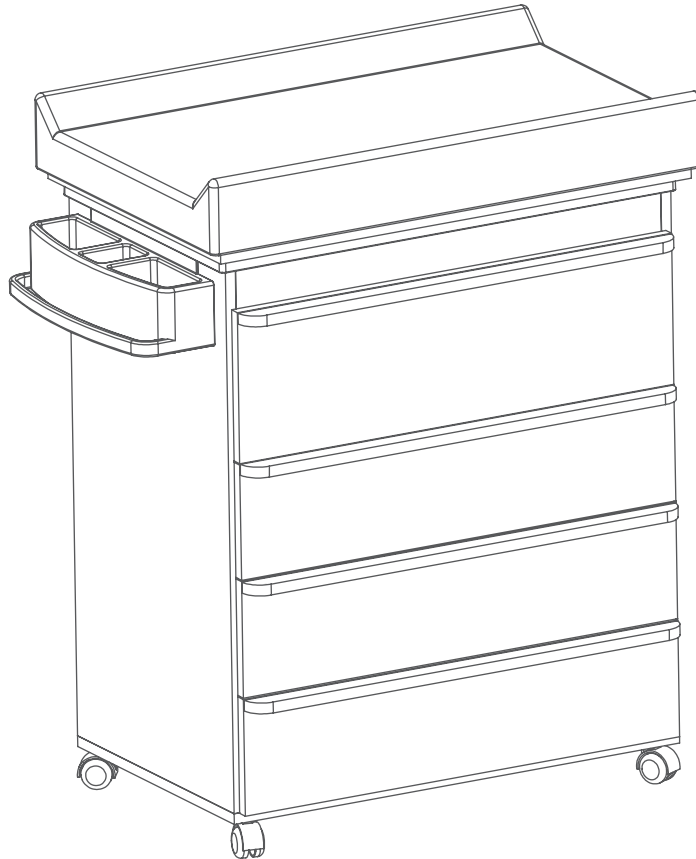

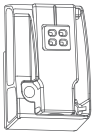
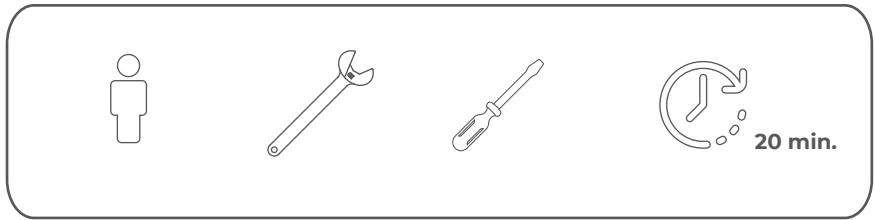

**C08149  
AX1**

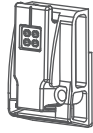

**C08148  
BX1**

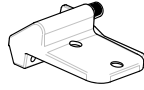

**C08150  
CX1**

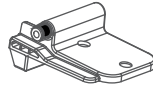

**C08151  
DX1**



**C08353  
EX1**

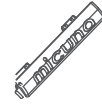

**C08354  
FX1**



**C04514  
GX4**

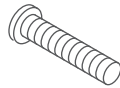

**C00197  
HX2  
M6X35**

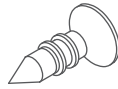

**C00205  
IX4  
M19X13**

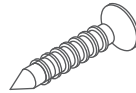

**C02250  
JX4  
M19X25**



**C04512  
KX4**



**LX2**



**MX2**



**C14126  
NX1**

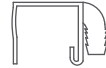

**C14127  
OX1**

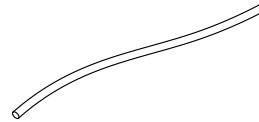

**C14100  
PX1**

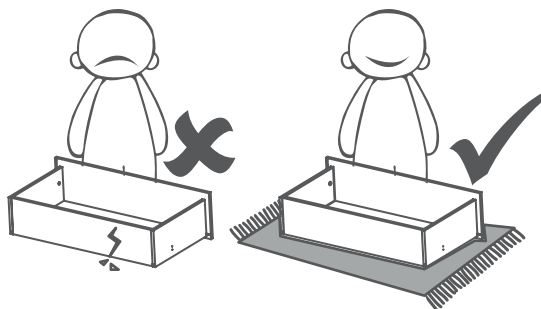
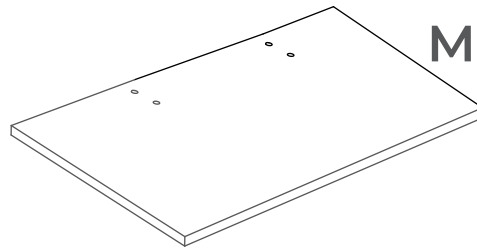
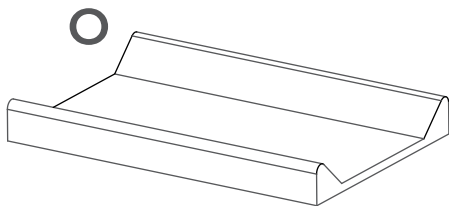

# 1



C04514  
GX4



C04512  
KX4

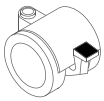

LX2



MX2

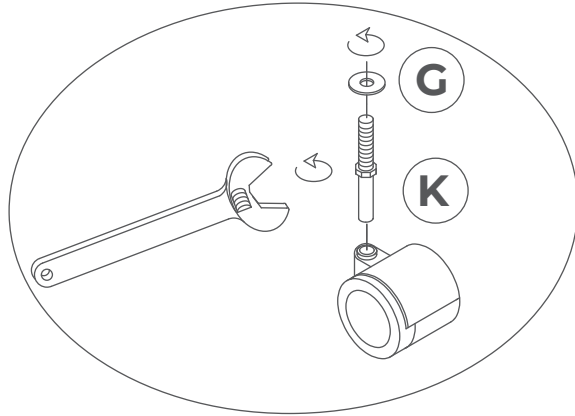

X 4

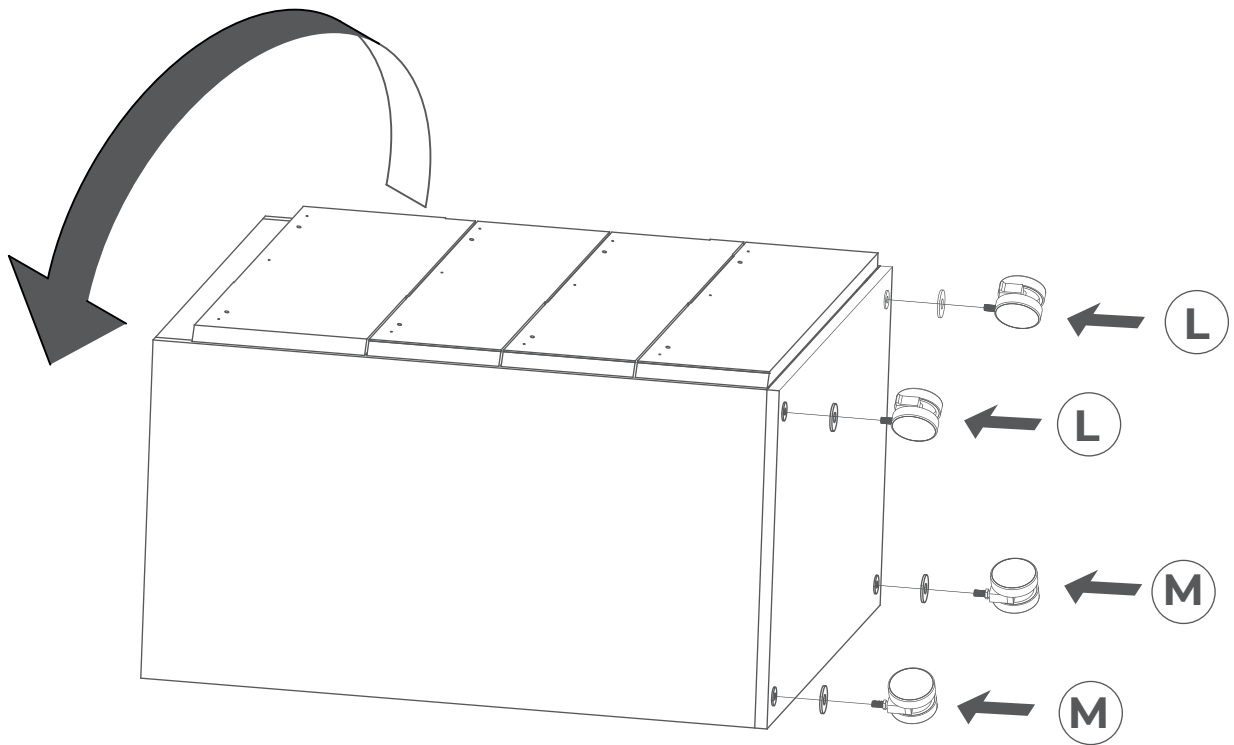

2

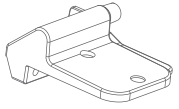

C08150  
CX1

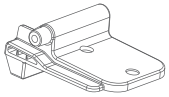

C08151  
DX1



C00205  
IX4  
M19X13

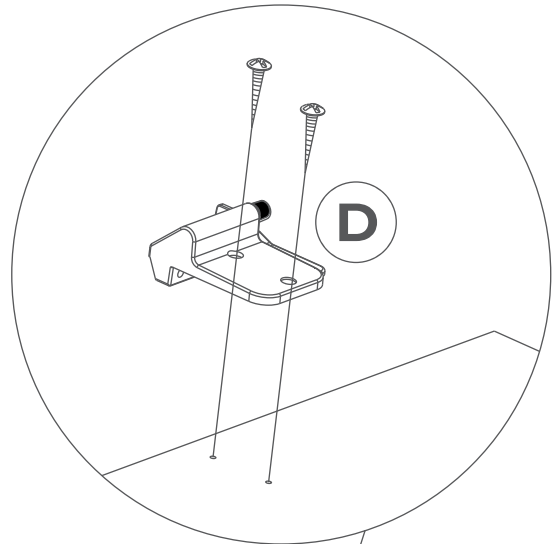

**ATTENTION !!!!**

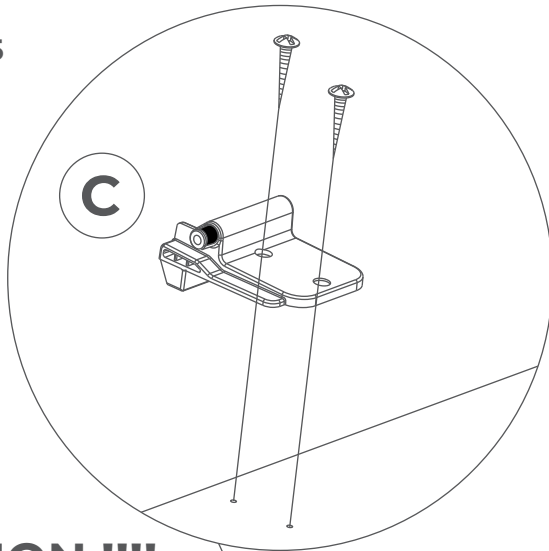

**ATTENTION !!!!**

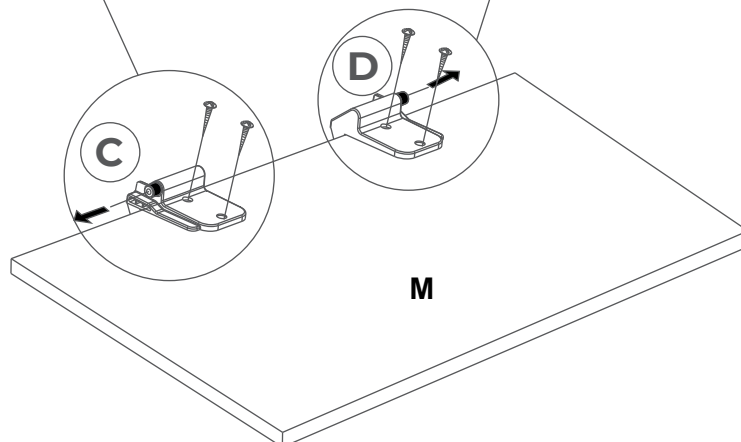

# 3

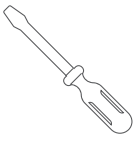

**C02250**  
**JX4**  
**M19X25**

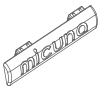

**C08353**  
**EX1**



**C08354**  
**FX1**

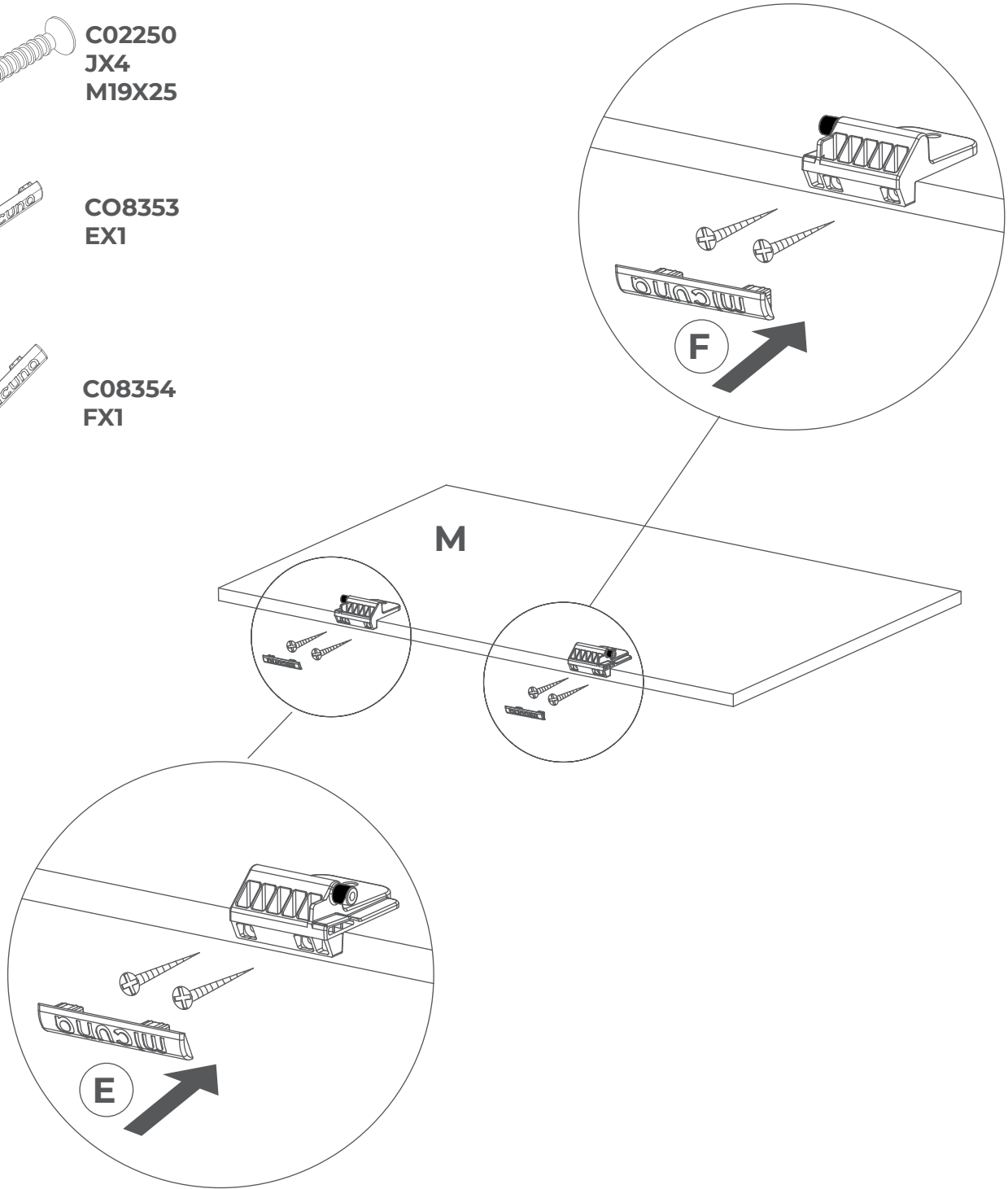

4

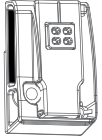

**C08149  
AX1**

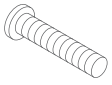

**C00197  
HX2  
M6X35**



**C08148  
BX1**

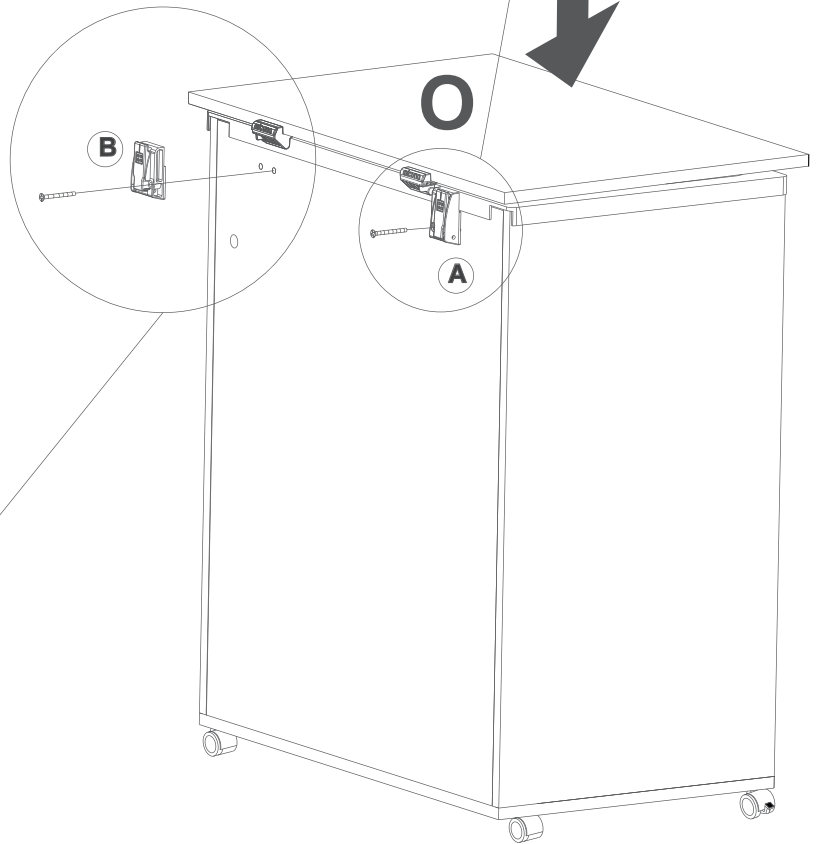
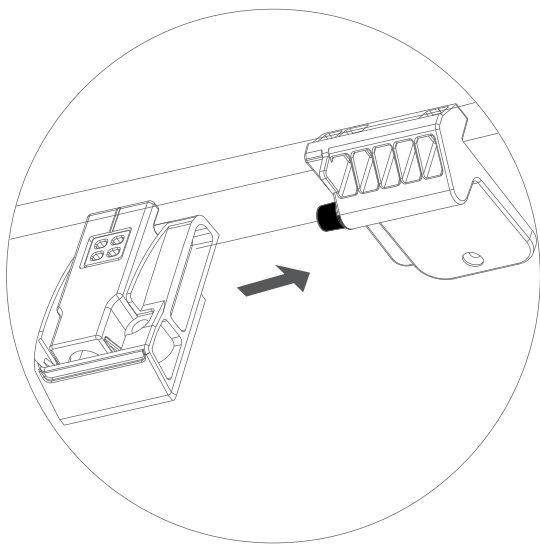
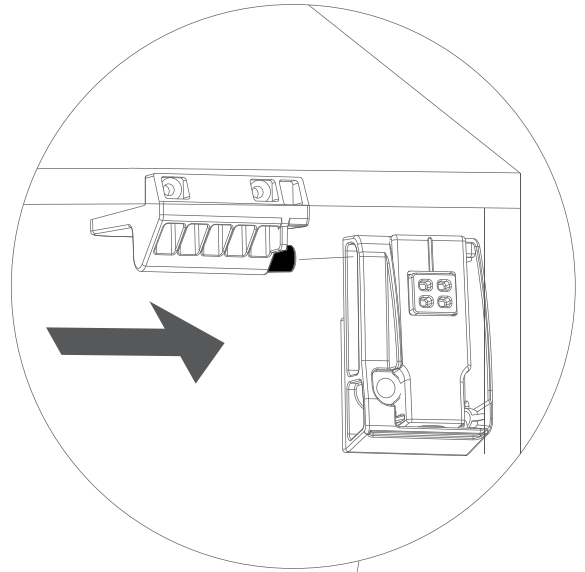

# 5

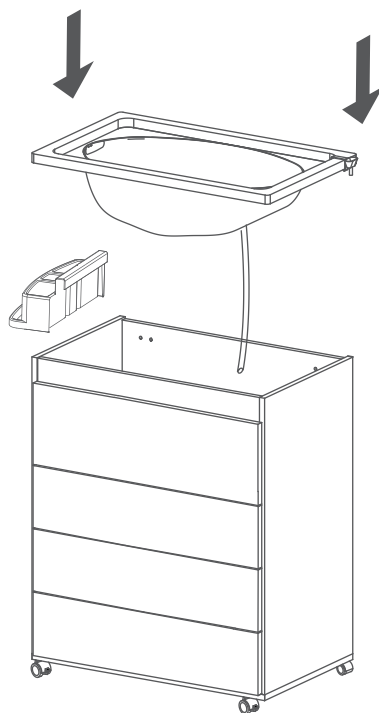

## OPCIÓN A

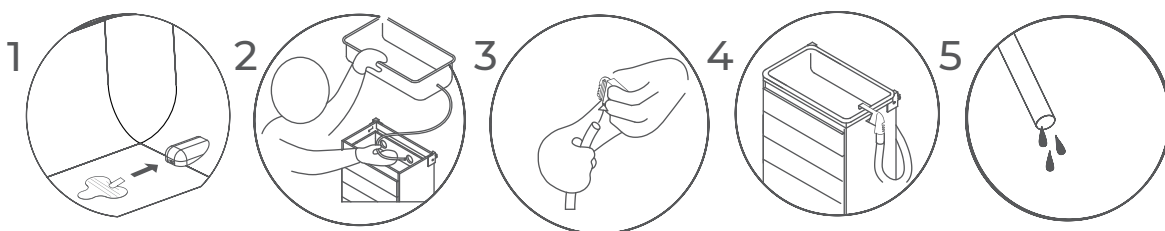

**IMPORTANTE!!! REVISAR QUE EL TUBO NO QUEDE PLEGADO PARA SU CORRECTO FUNCIONAMIENTO!!!**

**IMPORTANT!!! CHECK THAT THE TUBE DOES NOT REMAIN FOLDED FOR ITS CORRECT OPERATION!!!**

## OPCIÓN B

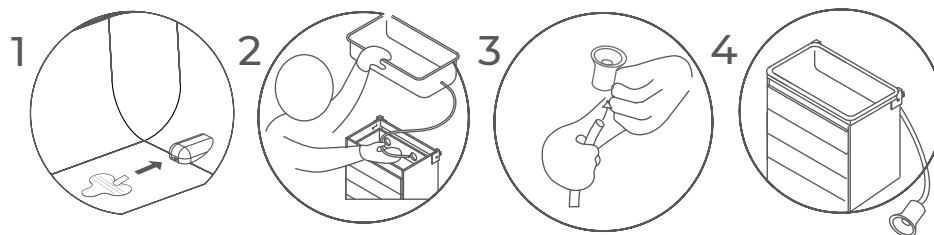

**ATENCIÓN!! QUITAR TAPÓN ÚNICAMENTE PARA DESAGUAR LA CUBETA**

**ATTENTION!! REMOVE PLUG ONLY TO DRAIN THE BUCKET**

## 6a SISTEMA DE FRENO CAJÓN DRAWER BRAKE SYSTEM

ATENCIÓN!!! SOLO EN CASO DE MAL FUNCIONAMIENTO  
ATTENTION!!! ONLY IN CASE OF BAD OPERATION

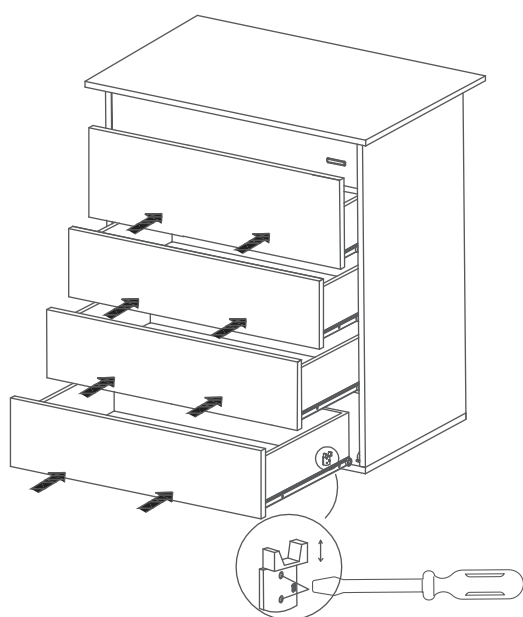
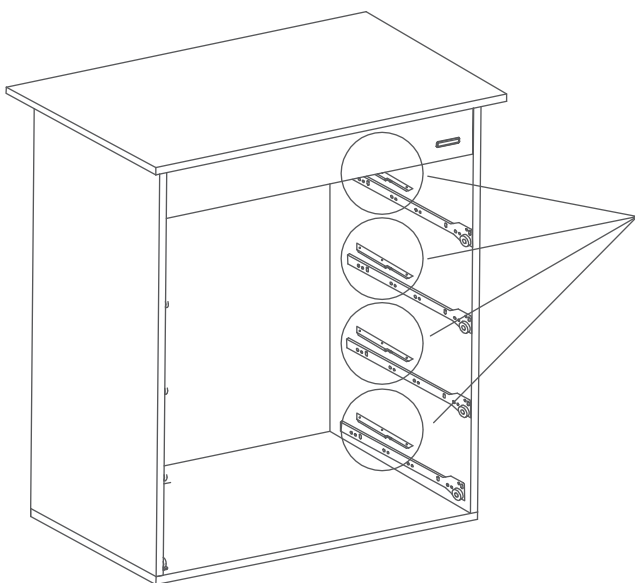

↑  
·CLICK  
·CLICK  
·CLICK  
·POSICIÓN N°3: OK  
↓



POSICIÓN  
OK  
CENTRADO



6b

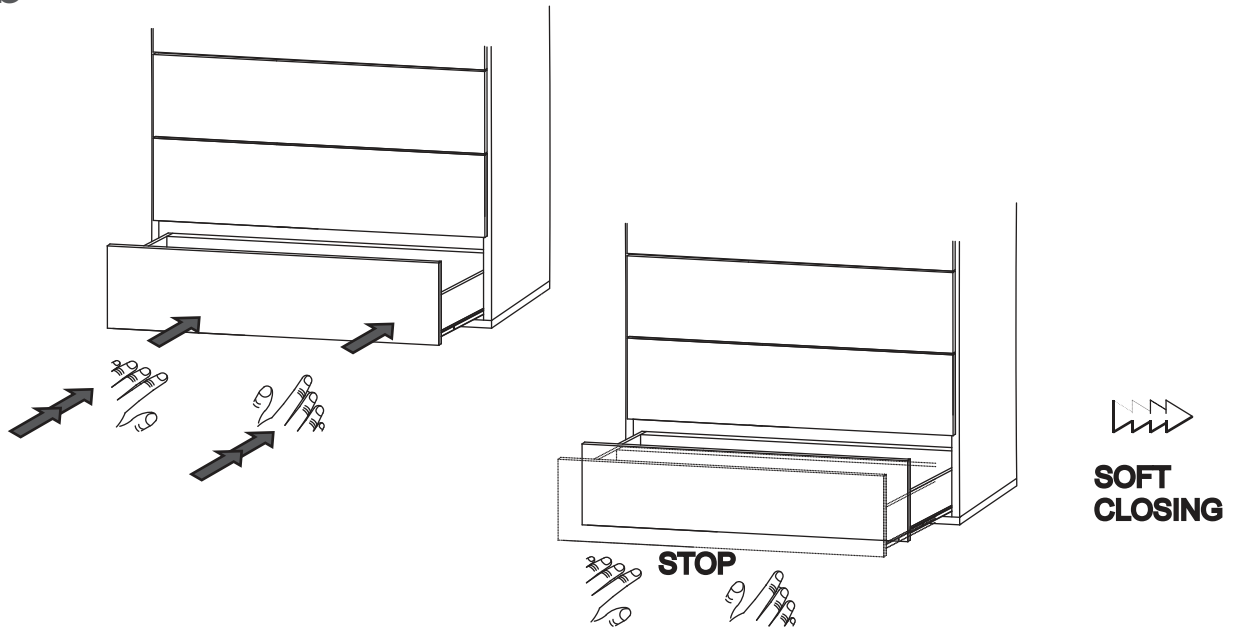

7

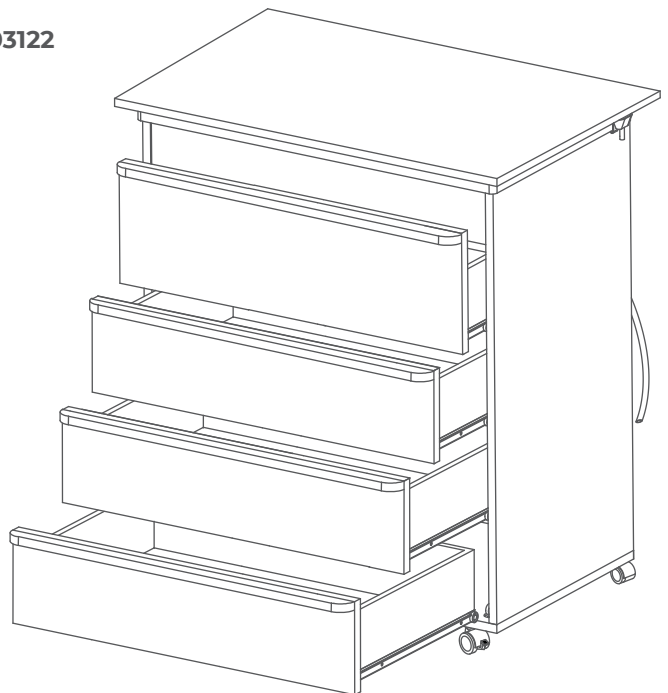
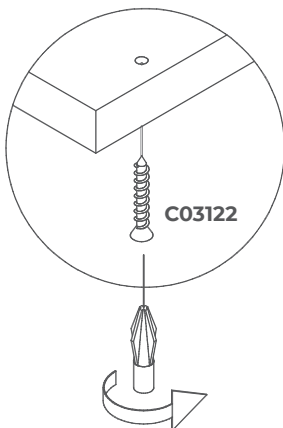
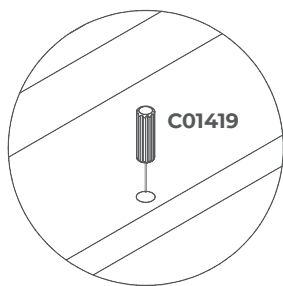
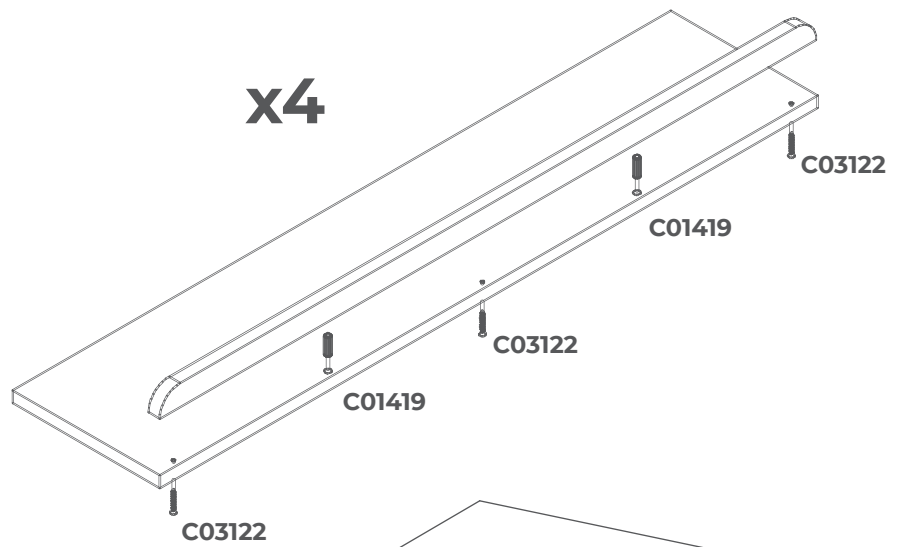
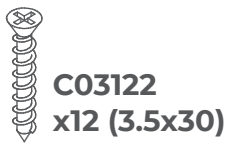

8

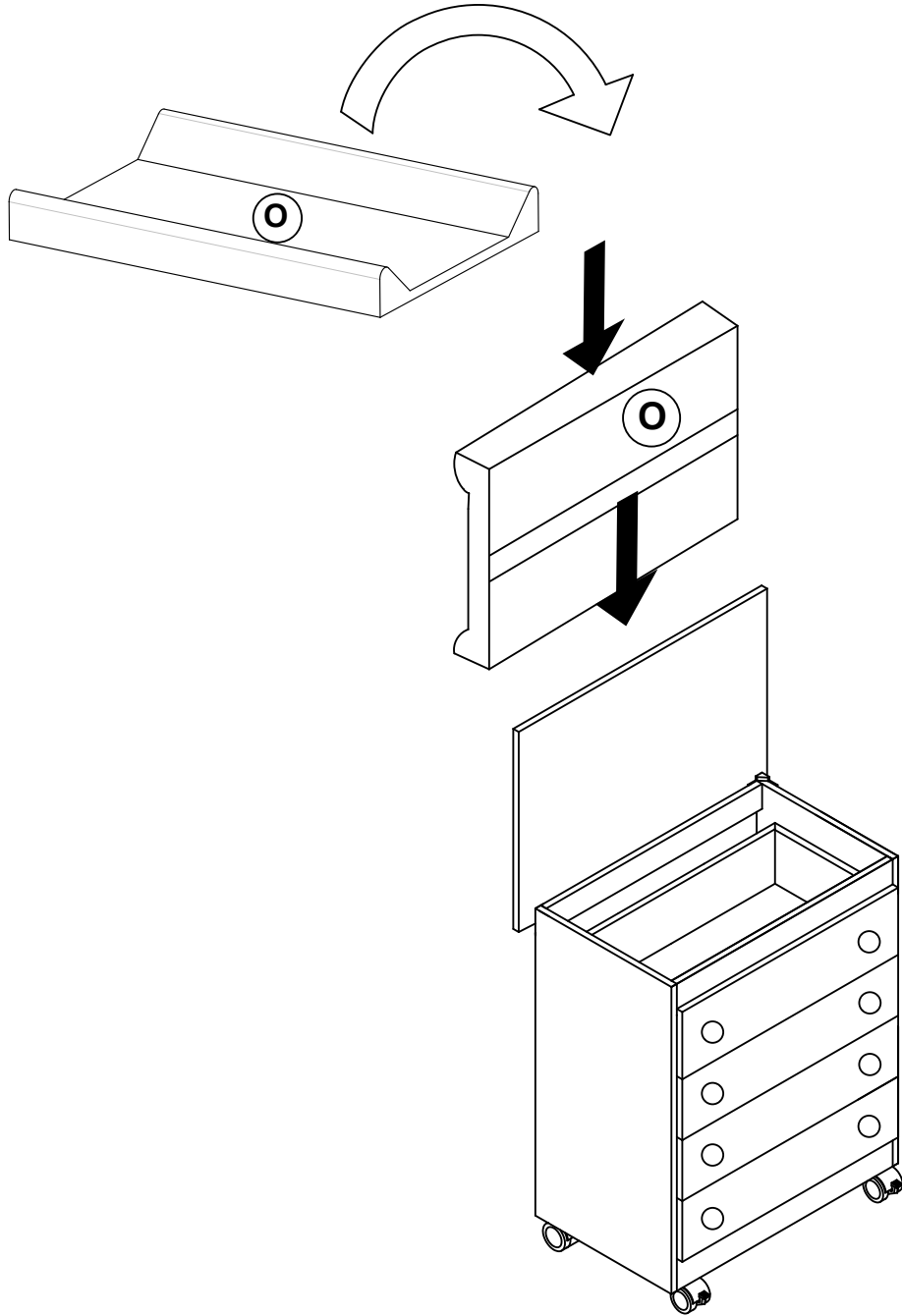

- E** USTED HA ADQUIRIDO UN PRODUCTO DE MICUNA, Y POR TANTO DEBE SABER:
- GB** YOU HAVE BOUGHT A MICUNA PRODUCT SO YOU SHOULD KNOW THAT:
- F** VOUS AVEZ ACHETÉ UN PRODUIT MICUNA ALORS VOUS DEVRIEZ CONNAÎTRE QUE:
- I** AVETE ACQUISTATO UN PRODOTTO MICUNA QUINDI E' IMPORTANTE SAPERE :
- P** ADQUIRIU UM PRODUTO MICUNA E, PORTANTO, DEVE SABER:
- R** ВЫ ПРИОБРЕЛИ ПРОДУКТ MICUNA, И ПОЭТОМУ ВАМ СЛЕДУЕТ ЗНАТЬ : :
- A** ہتفرعم مكيلع اذلو Micuna نم جتنم ىلع متلصح دق:

## • ES • ATENCIÓN



### ADVERTENCIA: NO DEJAR AL NIÑO DESATENDIDO.

- Todas las uniones de montaje deben ser correctamente apretadas y revisadas regularmente

- Ser consciente del riesgo de fuego abierto, y otras fuentes de calor, tales como radiadores incandescentes, estufas, etc. próximos al cambiador. No exponer el Mueble a ningún tipo de fuente de calor.
- Este cambiador sólo debe ser utilizado con la almohadilla proporcionada, ya que las medidas y barreras son las adecuadas
- Este cambiador no debe ser fijado en la pared
- Las ruedas deben estar bloqueadas cuando el cambiador esté en uso
- 15 Kg es el peso máximo del niño para el cual el producto está destinado
- Cualquier componente adicional o recambio debe ser adquirido a micuna.
- No utilizar este cambiador cuando cualquier parte esté rota, rasgada o perdida
- Si el cambiador presenta arrugas al ser desembalado, aplicar moderadamente aire caliente a una distancia aproximada de 20 cms para recuperar su forma original

### INSTRUCCIONES PARA EL USO CORRECTO DE LA BAÑERA.

- Usar siempre la bañera con la manguera del desagüe bien colocada.
- A la hora de vaciar la bañera coloque un recipiente al final de la manguera del desagüe.
- Lavar el tapizado con agua y jabón, nunca con productos corrosivos, químicos, disolventes, alcohol....

MICUNA NO SE HACE RESPONSABLE DE LOS DAÑOS QUE SE ORIGINEN EN EL MUEBLE NI A SU CONTENIDO, POR LA INCORRECTA COLOCACIÓN O USO DE LA MANGUERA DEL DESAGÜE.

## • GB • WARNING



### WARNING: DO NOT LEAVE CHILD UNATTENDED.

- All joints must be properly mounted and tightened and screened regularly
- Be aware of the risk of an open fire and other heat sources such as radiators, stoves, etc.. placed close to the baby-changer. Do not expose the cabinet to any type of heat source.
- This baby-changer should only be used with the mattress provided, as the measures of it and the barriers are adequate
- This changer can not be fixed to the wall
- The wheels must be locked when the changer is in use
- 15 kg is the maximum weight of the child for whom the product is intended
- Any additional components or parts must be purchased by micuna
- Do not use this changer when any part is broken, torn or missing
- If the changing mat has wrinkles when unpacking, apply moderately hot air at a distance of approximately 20 cm to recover its original shape

### INSTRUCTIONS FOR PROPER USE OF THE TUB.

- Always use the tub with the drain pipe properly seated.
- When emptying the bath place a container at the end of the drain pipe
- Wash the upholstery with soap and water, never with corrosives, chemicals, solvents, alcohol ....

### MICUNA NOT LIABLE FOR DAMAGES ARISING BY INCORRECT

INSTALLATION OR USE OF THE DRAIN PIPE IN THE CABINET OR THE CONTENT,

## • IT • AVVERTENZA



### AVVERTENZA: NON LASCIARE IL BAMBINO INCUSTODITO.

- Tutte le parti assemblate devono essere correttamente montate e revisionate regolarmente
- Essere consapevole del rischio del fuoco acceso, e altre fonti di calore come radiatori con resistenze incandescenti, stufe ecc.. in prossimità del fasciatoio. Non esporre a nessun tipo di emettore di calore.
- Il fasciatoio deve essere utilizzato con un materassino proporzionato e che le misure e le barriere siano adeguate
- Il fasciatoio non deve essere fissato alla parete
- Le ruote devono essere bloccate quando si usa il fasciatoio
- 15 Kg. È il peso massimo del bambino per il quale il prodotto è destinato
- Qualsiasi componente aggiuntivo o di ricambio deve essere acquistato da Micuna
- Non utilizzare il fasciatoio quando qualsiasi parte è rotta, strappata o smarrita
- Se il fasciatoio ha grinze quando sia disimballato, applicare moderatamente area calda da una distanza approssimativa di 20cms per recuperare la sua forma originale.

### ISTRUZIONI PER L'USO CORRETTO DEL BAGNETTO

- Usare sempre il bagnetto con il tubo di scarico ben collocato
- Al momento di svuotare il bagnetto collocare un recipiente alla fine del tubo di scarico.
- Lavare la tappezzeria con acqua e sapone, non con prodotti corrosivi, chimici, solventi o alcool....

MICUNA NON SI RITIENE RESPONSABILE DEI DANNI CHE SI POSSONO ORIGINARE NE SUL MOBILE NE SUL CONTENITORE, PER L'INCORRETTA COLLOCAZIONE O PER L'USO NON CORRETTO DEL TUBO DI SCARICO.

## • PT • ATENÇÃO



### ATENÇÃO: NUNCA DEIXE O BEBÉ SEM VIGILÂNCIA.

- Verifique periodicamente as peças e os fechos e aperte-os se necessário.
- Tenha em consideração os riscos provocados pelas chamas ou por outras fontes de calor, tais como aquecedores eléctricos, caloríferos a gás, etc., quando nas proximidades deste produto.
- Não expor o o mobiliário a nenhum tipo de fonte de calor.
- Este fraldário/mudador deve ser utilizado unicamente com o muda fraldas incluído, pois são estas as medidas e a altura dos laterais adequados para este produto.
- As rodas devem estar bloqueadas enquanto utiliza este produto como banheira/fraldário/mudador
- Este fraldário/mudador está indicado para crianças até um peso máximo de 15 Kg.
- Utilize exclusivamente acessórios e peças de substituição fornecidos pela Micuna.
- Não utilize este produto qualquer um dos seus componentes estiver rasgado, danificado ou em falta.
- Se o mudador apresentar dobras ("rugas") ao ser desembalado, aplicar moderadamente ar quente (por exemplo do secador de cabelo) a uma distância aproximada de 20 cm para recuperar a sua forma original.

### INSTRUÇÕES PARA O USO CORRECTO DA BANHEIRA

- Use sempre a banheira com o tubo de escoamento da água bem colocado.
- Para esvaziar a banheira, coloque um recipiente no fim do tubo de escoamento de água.
- Lave o fraldário/mudador com água e sabão. Nunca utilize produtos corrosivos, químicos, dissolventes ou álcool.

A MICUNA NÃO É RESPONSÁVEL PELOS DANOS CAUSADOS NO MÓVEL- BANHEIRA NEM NO SEU CONTEÚDO, PELA INCORRECTA COLOCAÇÃO OU USO DO TUBO DE ESCOAMENTO DE ÁGUA.

## • R • ВНИМАНИЕ



ВНИМАНИЕ! НЕ ОСТАВЛЯЙТЕ РЕБЕНКА БЕЗ ПРИСМОТРА

-Все соединения должны быть собраны и затянуты должным образом и проверяться регулярно

-Не забывайте об опасности открытого огня и других источников тепла, таких, как радиаторы, плиты и др., размещенных рядом с пеленальнымкомодом.

Не подвергайте мебель воздействию от источника тепла любого типа.

-Пеленальный комод нельзя прикреплять к стене

-При использовании пеленального комода колеса должны быть заблокированы

-Максимальный вес ребенка, для которого предназначено изделие, 15 кг

-Любые дополнительные комплектующие или части должны быть приобретены

у производителя MICUNA

ИНСТРУКЦИЯ ПО ПРАВИЛЬНОМУ ИСПОЛЬЗОВАНИЮ ВАННОЧКИ

-Всегда используйте ванночку с надежно закрепленной трубкой слива

-Если при расправке комода пеленальный матрасик имеет складки, поднесите матрасик к умеренно горячему воздуху на расстоянии приблизительно 20 см для восстановления первоначальной формы матрасика

-Во время слива воды из ванночки поместите трубку слива в емкость

-Мойте обивку матрасика с мылом и водой, не используйте едкие вещества, химикаты, растворители, спирт...

MICUNA НЕ НЕСЕТ ОТВЕТСТВЕННОСТИ ЗА УЩЕРБ, НАНЕСЕННЫЙ ПЕЛЕНАЛЬНОМУ КОМОДУ ИЛИ ЕГО СОДЕРЖИМОМУ, ВЫЗВАННЫЙ НЕПРАВИЛЬНОЙ УСТАНОВКОЙ ИЛИ НЕПРАВИЛЬНЫМ ИСПОЛЬЗОВАНИЕМ СЛИВНОЙ ТРУБЫ

## • FR • AVERTISSEMENT



AVERTISSEMENT : NE PAS LAISSER L'ENFANT SANS ATTENTION

- Toutes les unions(réunions) de montage doivent correctement être serrées et révisées régulièrement

- Comprendre le risque de feu ouvert, et d'autres fontaines(sources) de chaleur, telles que des radiateurs incandescentes, poêles, etc.. proches de l'échangeur. Ne pas

exposer le meuble à une source de chaleur.

- Cet échangeur seul doit être utilisé par le coussinet proportionné, puisque les mesures et les barrières sont les adéquates

- Cet échangeur ne doit pas être fixé dans le mur

- Les roues doivent être bloquées quand l'échangeur sera dans un usage

- 15 un kg est le poids maximal de l'enfant lequel le produit est destiné

- Si le plan de langer est ridée lors du déballage, appliquer de l'air modérément chaud à une distance d'environ 20 cm pour retrouver sa forme originale

DES INSTRUCTIONS POUR L'USAGE CORRECT DE LA BAIGNOIRE

- Utiliser toujours la baignoire avec le tuyau d'arrosage bien placé de l'écoulement.

- À l'heure de vider la baignoire placez un récipient à la fin du tuyau d'arrosage de l'écoulement

- Ne laver la tapisserie avec eau et savon, jamais avec des produits corrosifs, des chimistes, des solvants, un alcool

MICUNA NE DEVIET PAS RESPONSABLE DES DOMMAGES QUE PROVOQUEZ DANS LE MEUBLE NI À SON CONTENU, PAR L'INCORRECTE UN PLACEMENT OU UN USAGE DU TUYAU D'ARROSAGE DE L'ÉCOULEMENT

## • A •



تباقر نود مھدالوا او کفرتت الھابتنا

جتھلما نم تبیرقنا نارفال او فیفدتنا فزهجا لثم قرارحل رداصم لکو، لاعتشال اقولباق نم رذح  
ثمالسلل فتمؤلما تافاسجلما تارابتعال، اهل عباتلا شارفلا عم طوقف اھلمعتسا بجی قلواطلا فھنا

طئاجلاب قلواطلا فھنا مکاح نکتھم ال

اهلمعتسا دن ع قلواطلا لمارف نتیبشت بجی

لفظلا نزول غلک 15 وه نم ال لامعتسالل یصق ال دحلما

لامعتسال لبیق اديج ارق اءع جارمل ظفحا . ماه

ھایما فیرصت و ، ےیطاخلا لامعتسال او ببکرتلا نع عجتانلا رارضالا نع قلووسم ریغ Micuna نا

اھعجمجل اءاھو لمعتسا ، اھلما نم سطغملا غیرفت دن ع

سطغملا حجی حصللامعتسال تاداھرا

عحی حصل ا ققیرطلاب ھایما فیرصت بببنا نتیبشت دع اءاھ سطمغلا لمعتسا

اھعجمجل اءاھو لمعتسا ، اھلما نم سطغملا غیرفت دن ع

وا ، قبوڈملا وقئایمیلدا دا وملالمعتست ال طوقف اھلاونوب اصلما لمعتسا ، فنیظنلل

اعطق اھنم غنصرت یتلا تاچتھملا وا لوھلما

اعطق اھنم غنصرت یتلا تاچتھملا

ھایما فیرصت و ، ےیطاخلا لامعتسال او ببکرتلا نع عجتانلا رارضالا نع قلووسم ریغ Micuna نا