

# -IMPORTANTE: A CONSERVAR PARA FUTURAS CONSULTAS. LÉASE ATENTAMENTE.

ES

EN -IMPORTANT: PLEASE KEEP FOR FUTURE REFERENCE. READ CAREFULLY.

FR -ATTENTION: CONSERVER POUR CONSULTER AU FUTUR.

IT -IMPORTANTE: LEGGERE ATTENTAMENTE LE ISTRUZIONI. TENERE PER FUTURE CONSULTAZIONE.

PT -IMPORTANTE: MANTENHA PARA FUTURAS CONSULTAS. LÉASE ATENTAMENTE.

R -ВАЖНО: СОХРАНИТЕ ДЛЯ ДАЛЬНЕЙШЕГО ИСПОЛЬЗОВАНИЯ . ВНИМАТЕЛЬНО ПРОЧИТИЕ .

A - ماه. ظرف اة ع ار ملل. أرقا ادي ج لبق لام عتسال

CN -重要事项: 保留以备将来参考, 请仔细阅读。

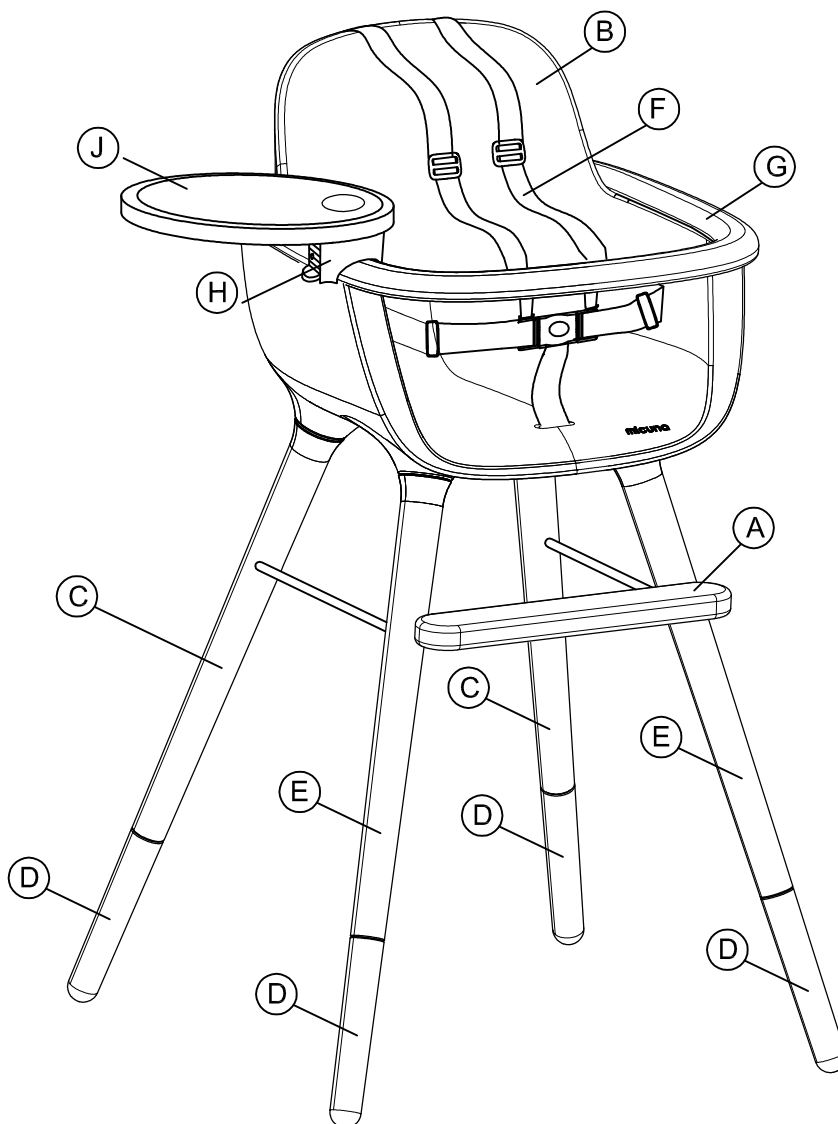

**OVO ORIGINAL ONE**  
**OVO ORIGINAL CITY**

**Instrucciones de Montaje**

**Fabricado en Valencia, España**

**micuna**  
magic ideas for children

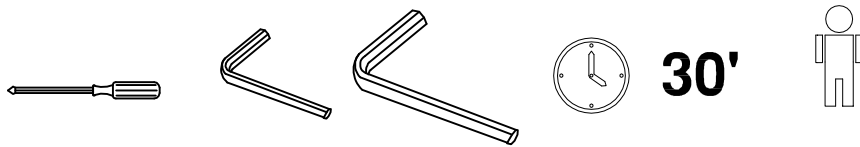

 <b>A X 1</b>	 <b>G X 1</b>	 <b>C07506 X1</b>	
 <b>B X 1</b>	 <b>C X 2</b>	 <b>C07914 X1</b>	
 <b>FX 1</b>	 <b>EX 2</b>	 <b>C07903 X4</b> <b>M6x10</b>	
 <b>DX 4</b>	 <b>JX 1</b>	 <b>C07504 X1</b> <b>M8x15</b>	
 <b>HX 1</b>	 <b>C11001 X2</b>	 <b>C11002 X2</b> <b>M6x45</b>	
	 <b>C04198 X2</b> <b>M6x30</b>	 <b>C08958 X1</b> <b>M8x30</b>	
	 <b>C10373 X4</b>	 <b>pag 12/12 6b</b> <b>5028905 X1</b>	
	<p><b>T-1771 OVO CITY</b></p>	<p><b>5023793</b></p> <p><b>pag 12/12 6a</b></p> <b>C08959 X6</b> <b>M8x10</b>	
	 <b>C10073 X4</b>		



ES



EN



FR

1.

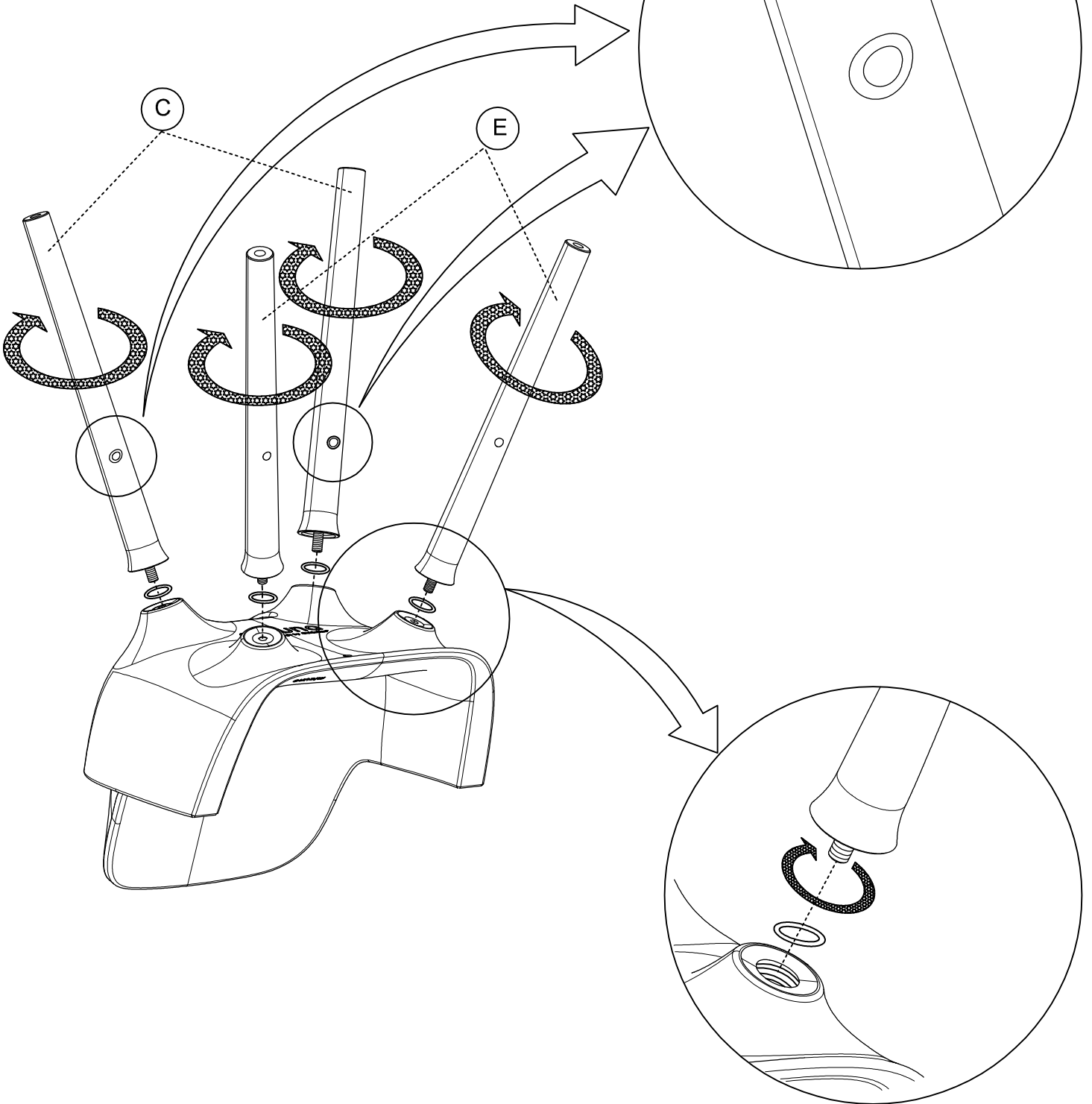
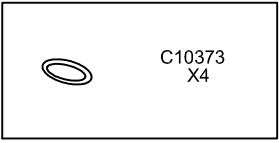
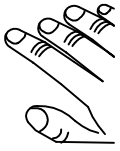

**2. OVO ORIGINAL ONE**

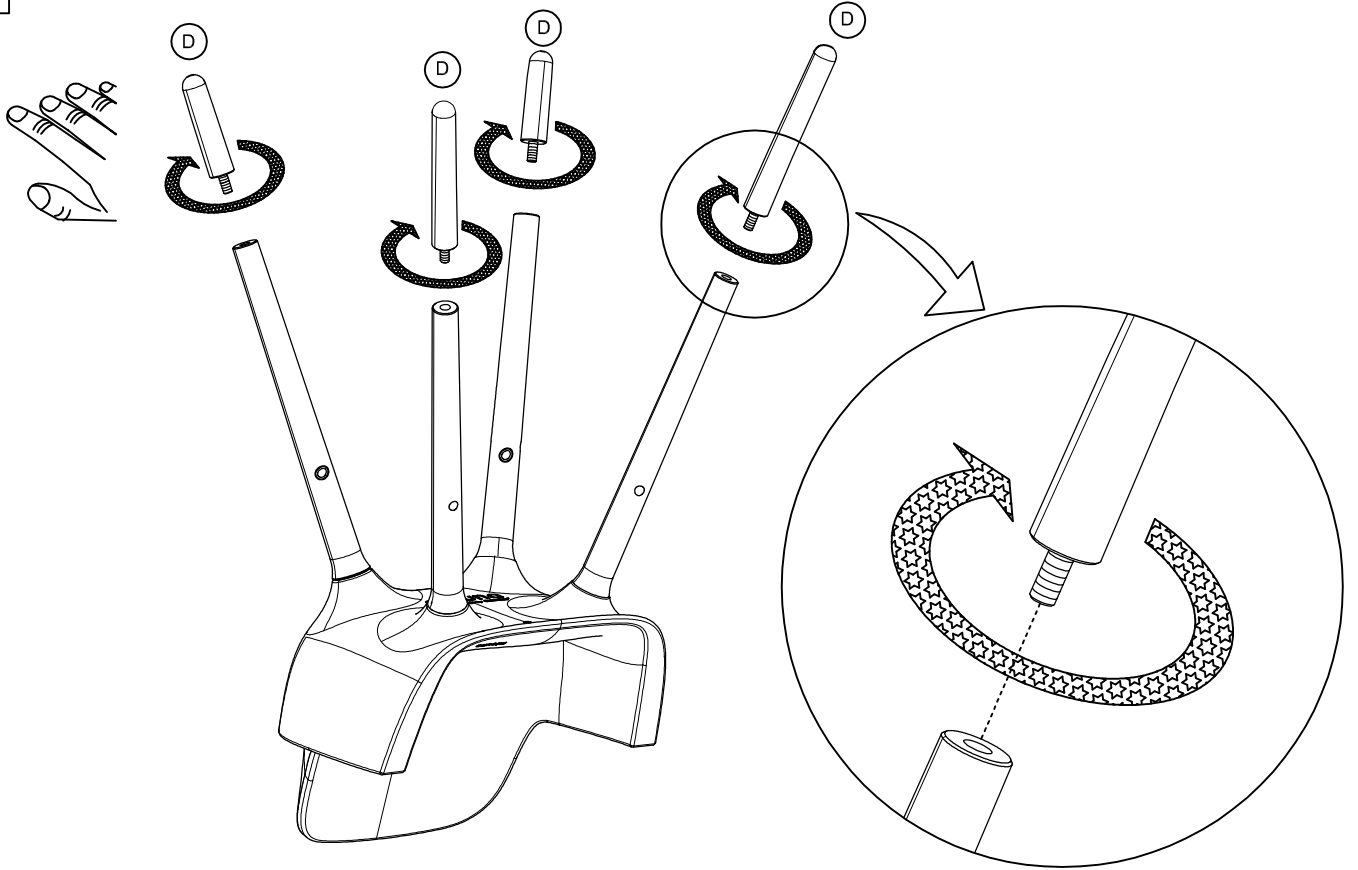

**2. OVO ORIGINAL CITY**

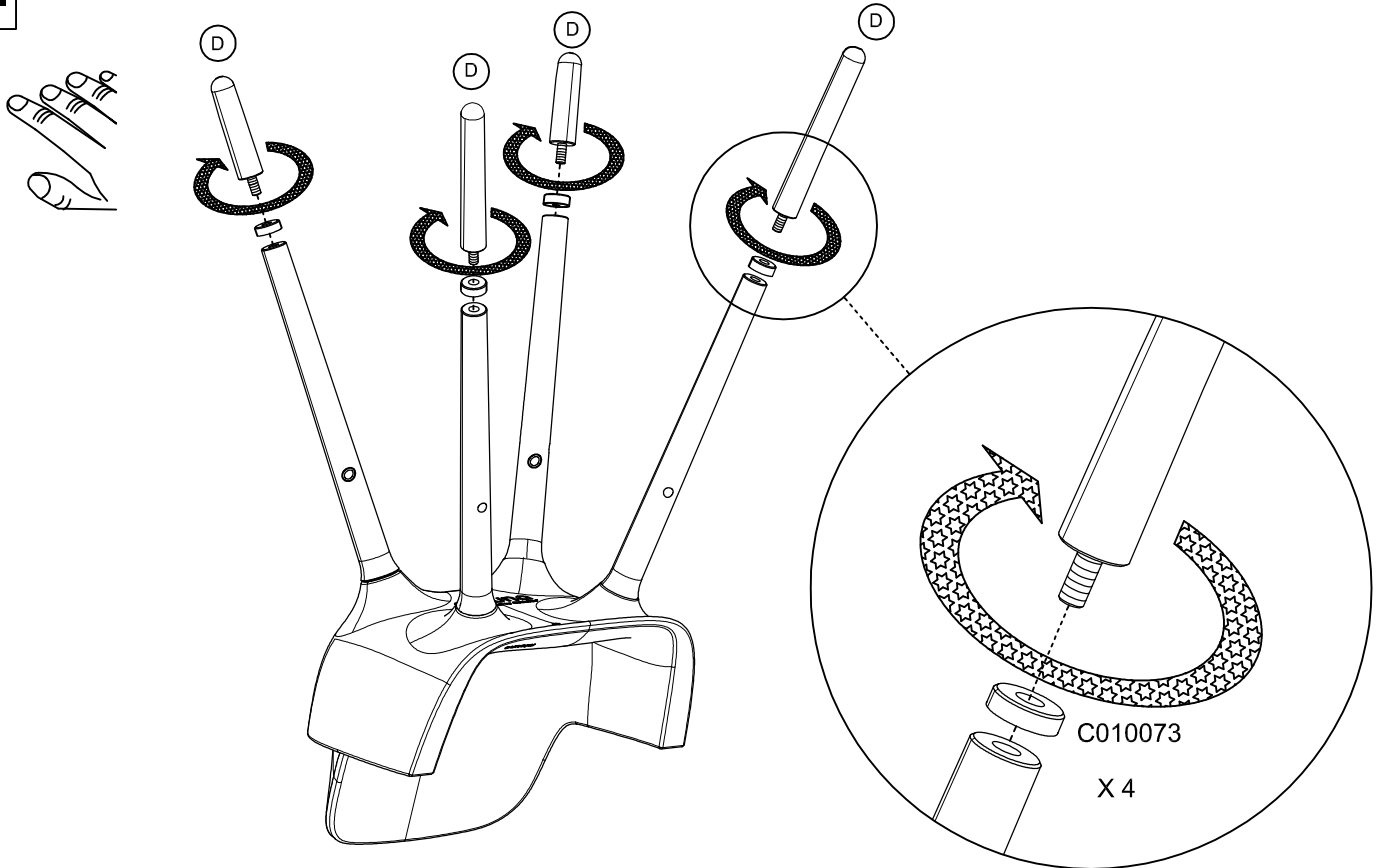

**OVO ORIGINAL CITY**



C10073  
X4

3.

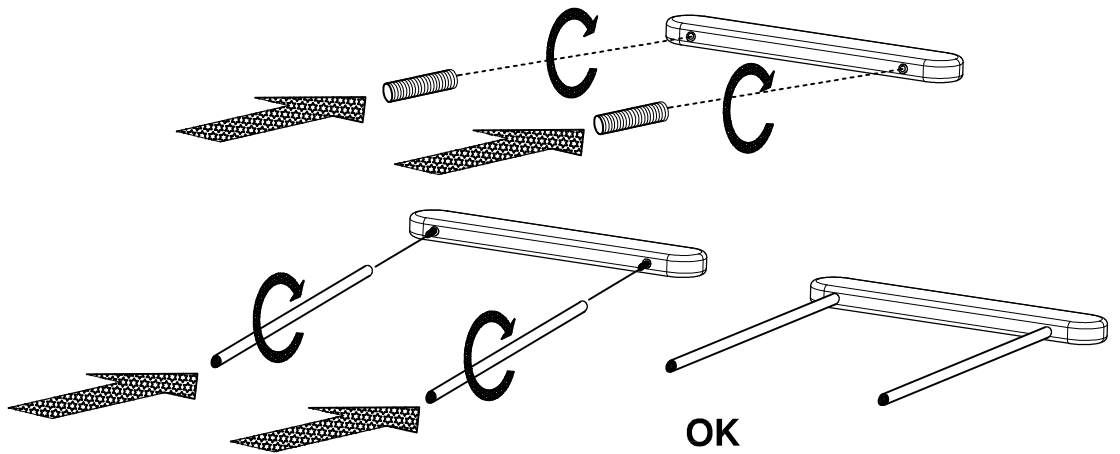
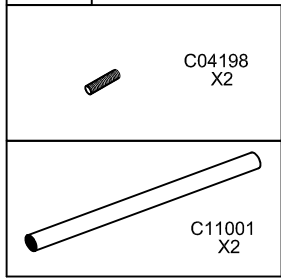

4.

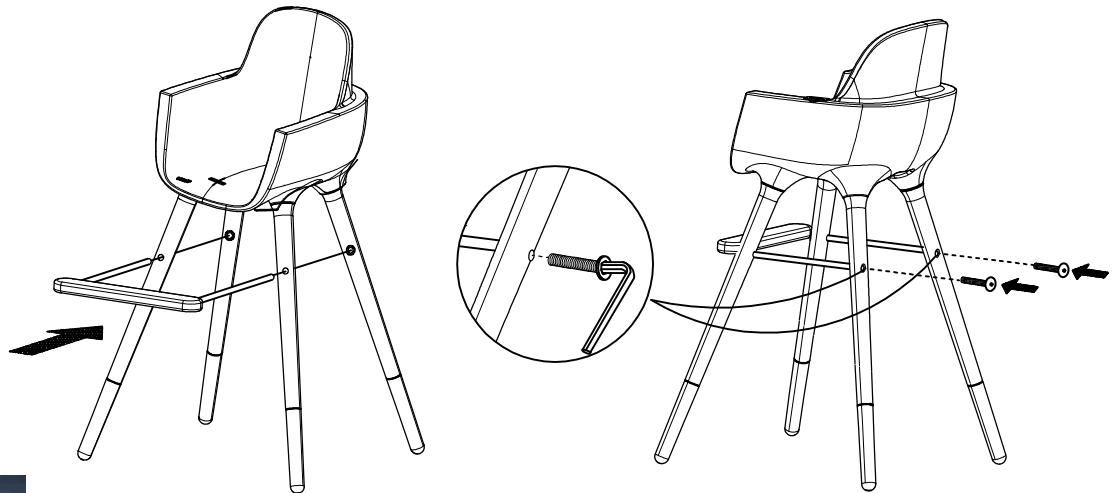
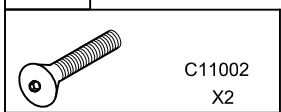

**IMPORTANT  
IMPORTANT  
IMPORTANT**

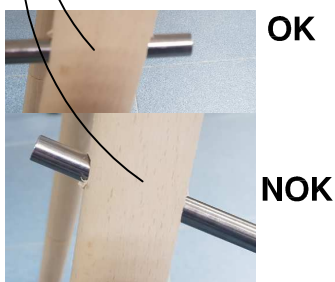
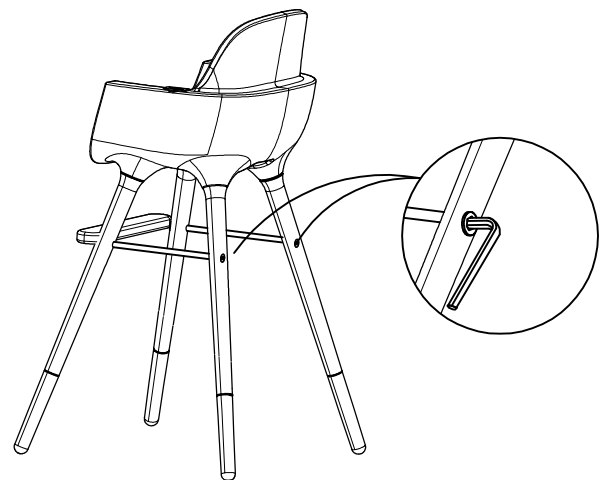

TORNILLO SISTEMA  
"NIVELACIÓN"  
SCREW "LEVELING"  
SYSTEM  
VIS DE SYSTEME  
"NIVELLEMENT"

5.

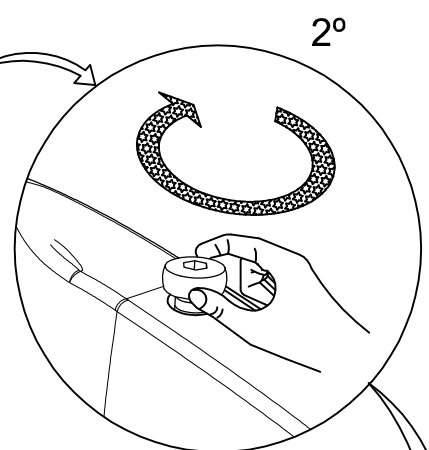
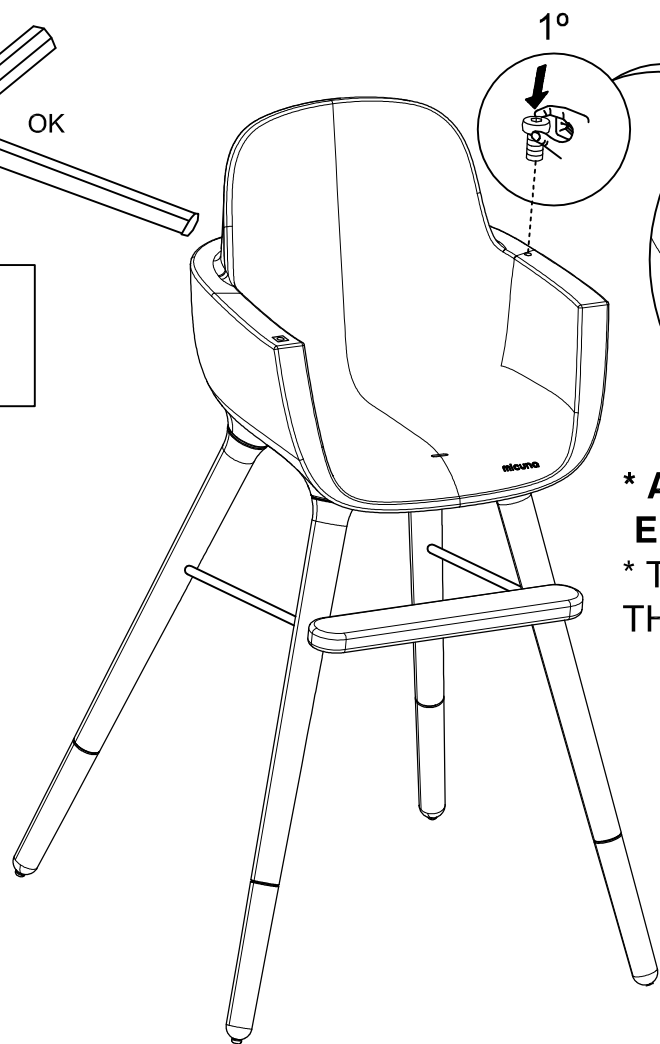
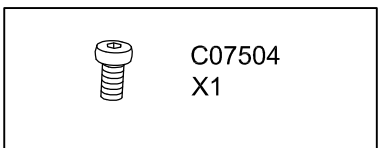
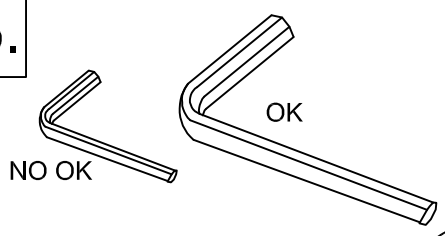

\* APRETAR HASTA EL FINAL  
\* TIGHTEN UP UNTIL THE END

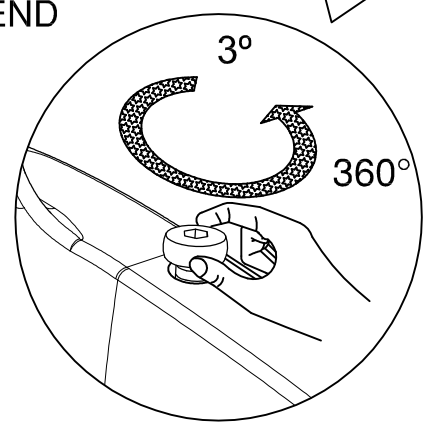

\* DESENROSCAR SÓLO 1 VUELTA ( 360° )  
\* UNSCREW ONLY 1 TURN ( 360° )

6.

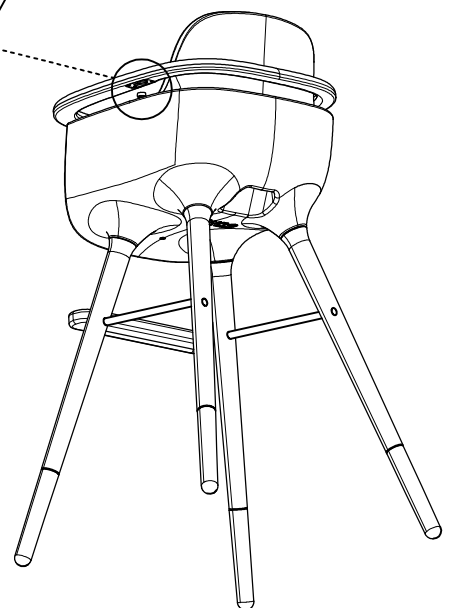
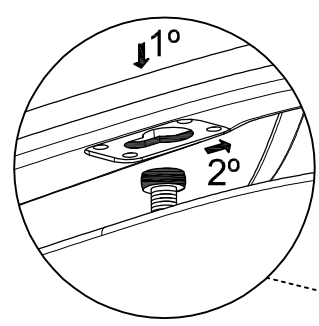
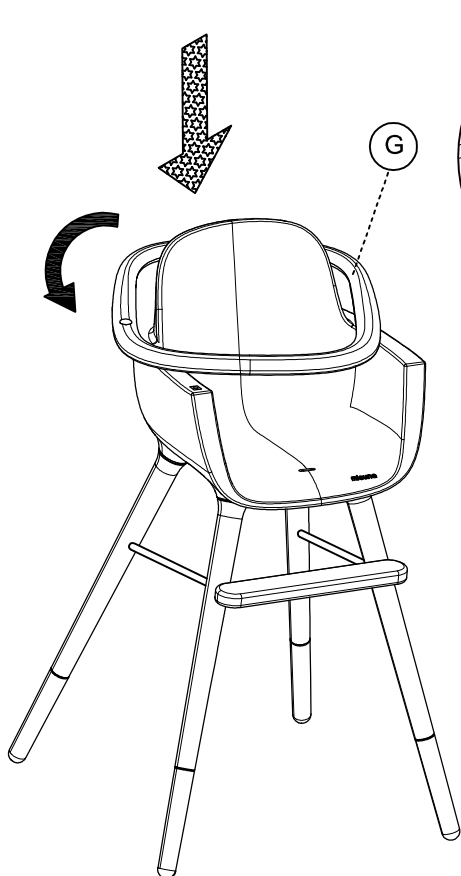

7.

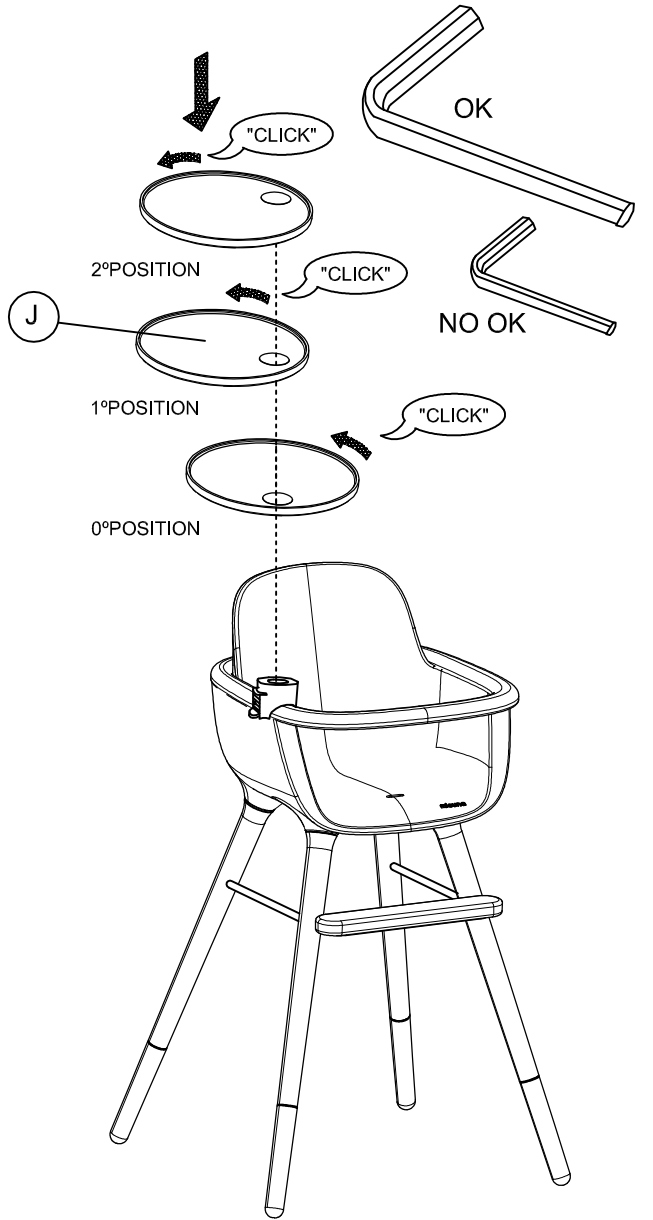
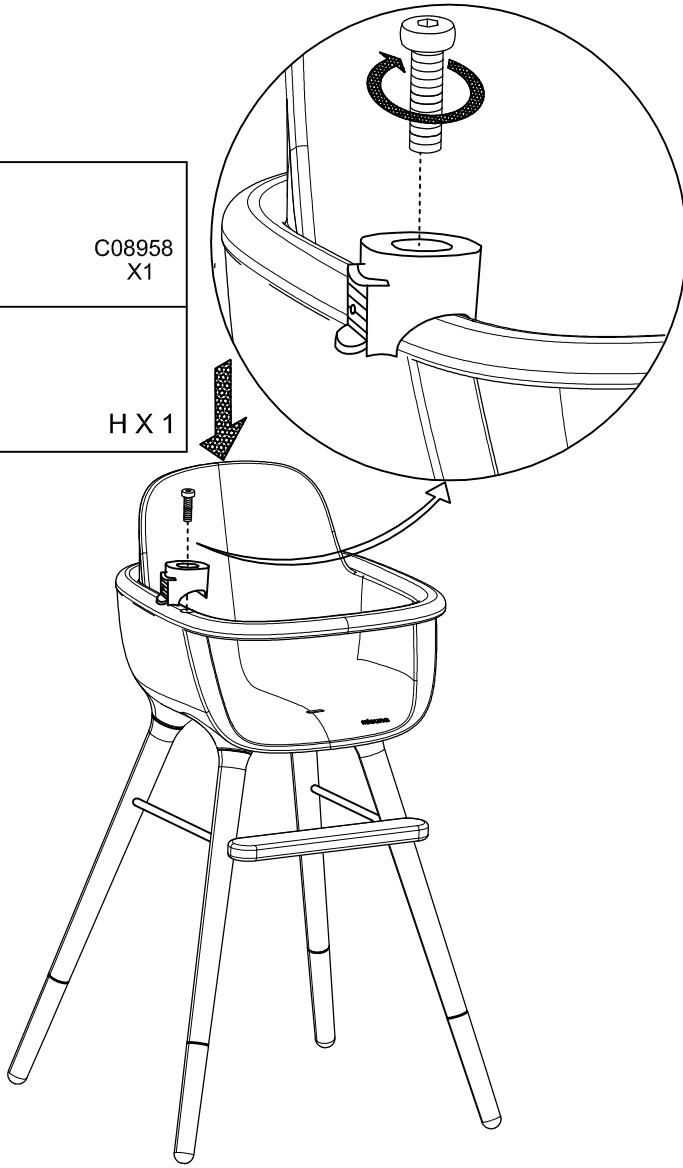
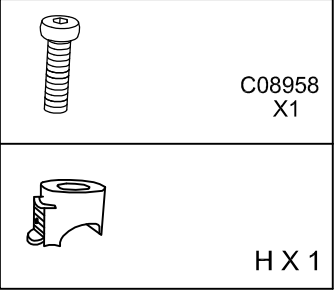

1



2

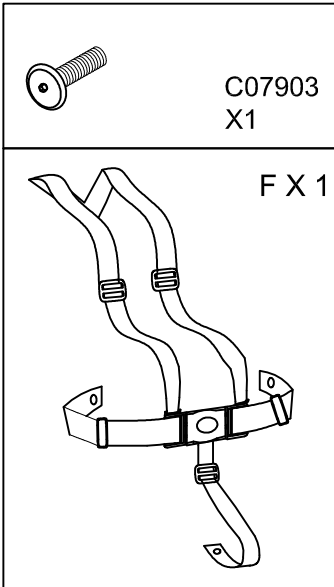

3



4

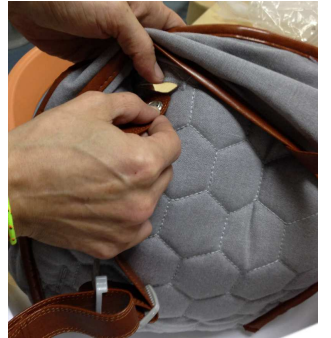

5



6



7



8

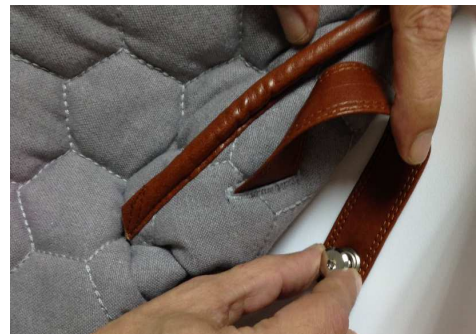

9



10



11



12



**\* DEJAR SIN ATORNILLAR HASTA EL PASO 9 (PAG.9)**  
**\* LEAVE UNSCREWED UNTIL STEP 9 (PAG.9)**





**\* MUY IMPORTANTE AJUSTAR CORREAS.**  
**\* VERY IMPORTANT TO ADJUST BELTS**

**8.**

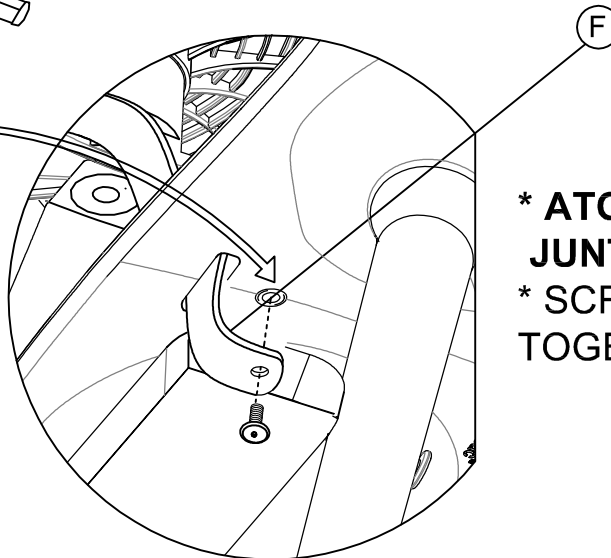
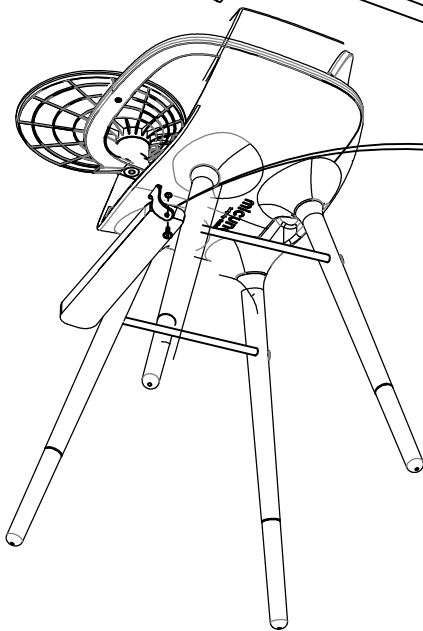
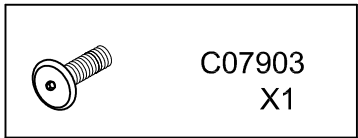
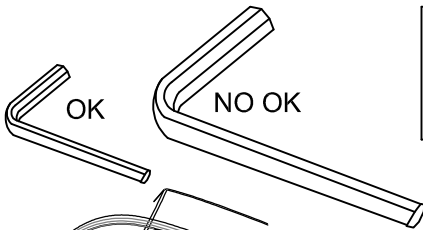

**\* ATORNILLAR  
JUNTOS F**  
**\* SCREW F,  
TOGETHER**

UNE-EN 14988:2018

## ADVERTENCIAS

1. Nunca deje al niño desatendido.
2. En caso de productos con sistema activo de retención: (Utilice siempre el sistema de sujeción).
3. No utilizar la trona hasta que el niño se mantenga sentado sin ayuda.
4. Existe un riesgo al situar el producto cerca del fuego o de otras fuentes importantes de calor.
5. Utilice el producto únicamente cuando todos sus componentes estén correctamente fijados y ajustados .
6. En caso de que se rompa alguna pieza, o se quiebre la trona no debe ser utilizada hasta su reparación.
7. Para su limpieza utilizar un paño suave humedecido, no utilizar productos abrasivos ni disolventes.
8. Riesgo de caída: Evite que el niño trepe por el producto.
9. Existe riesgo de vuelco si el niño apoya los pies en una mesa o cualquier otra estructura.

## AVERTISSEMENTS

1. Ne laissez jamais un enfant sans surveillance.
2. Dans le cas de produits avec système de retenue actif : (Toujours utiliser le système de fixation).
3. N'utilisez pas la chaise haute tant que l'enfant ne s'est pas assis sans aide.
4. Ne pas placer la chaise haute près d'un feu ou d'autres sources importantes de chaleur.
5. N'utilisez la chaise haute que lorsque tous ses composants sont correctement fixés et ajustés.
6. Si une pièce est cassée ou si la chaise haute est cassée, elle ne doit pas être utilisée avant d'avoir été réparée.
7. Pour la nettoyer, utilisez un chiffon doux et humide, n'utilisez pas de produits abrasifs ou de solvants.
8. Risque de chute : Empêcher l'enfant de grimper seul sur la chaise haute.
9. Il y a un risque de basculement si l'enfant pose ses pieds sur une table ou toute autre structure.

## WARNINGS

1. Never leave a child unattended.
2. In the case of products with an active restraint system: (Always use the attachment system).
3. Do not use the highchair/baby chair until the child has sat down without help.
4. Do not place the highchair near a fire or other major sources of heat.
5. Use the highchair only when all its components are properly attached and adjusted.
6. If a part is broken or the highchair is broken, it should not be used until it has been repaired.
7. To clean it, use a soft, damp cloth, do not use abrasive products or solvents.
8. Risk of falling: Prevent the child from climbing into the high chair alone.
9. There is a risk of tipping over if the child places his feet on a table or other structure.

## AVVERTENZE

1. Non lasciare mai il bambino incustodito.
2. In caso di prodotti con sistema di ritenzione attivo: (Utilizzare sempre il sistema di bloccaggio).
3. Non utilizzare il seggiolone finché il bambino non si siede senza aiuto.
4. Vi è il rischio di collocare il prodotto vicino a fuoco o altre importanti fonti di calore.
5. Utilizzare il prodotto solo quando tutti i suoi componenti sono correttamente fissati e regolati.
6. Nel caso in cui un pezzo è rotto, o il seggiolone è rotto, non dovrebbe essere utilizzato fino a quando non viene riparato.
7. Per la pulizia utilizzare un panno morbido inumidito, non utilizzare prodotti abrasivi o solventi.
8. Rischio di caduta: evitare che il bambino salga sul prodotto.
9. Vi è il rischio di ribaltamento se il bambino sostiene i piedi su un tavolo o qualsiasi altra struttura.

1.

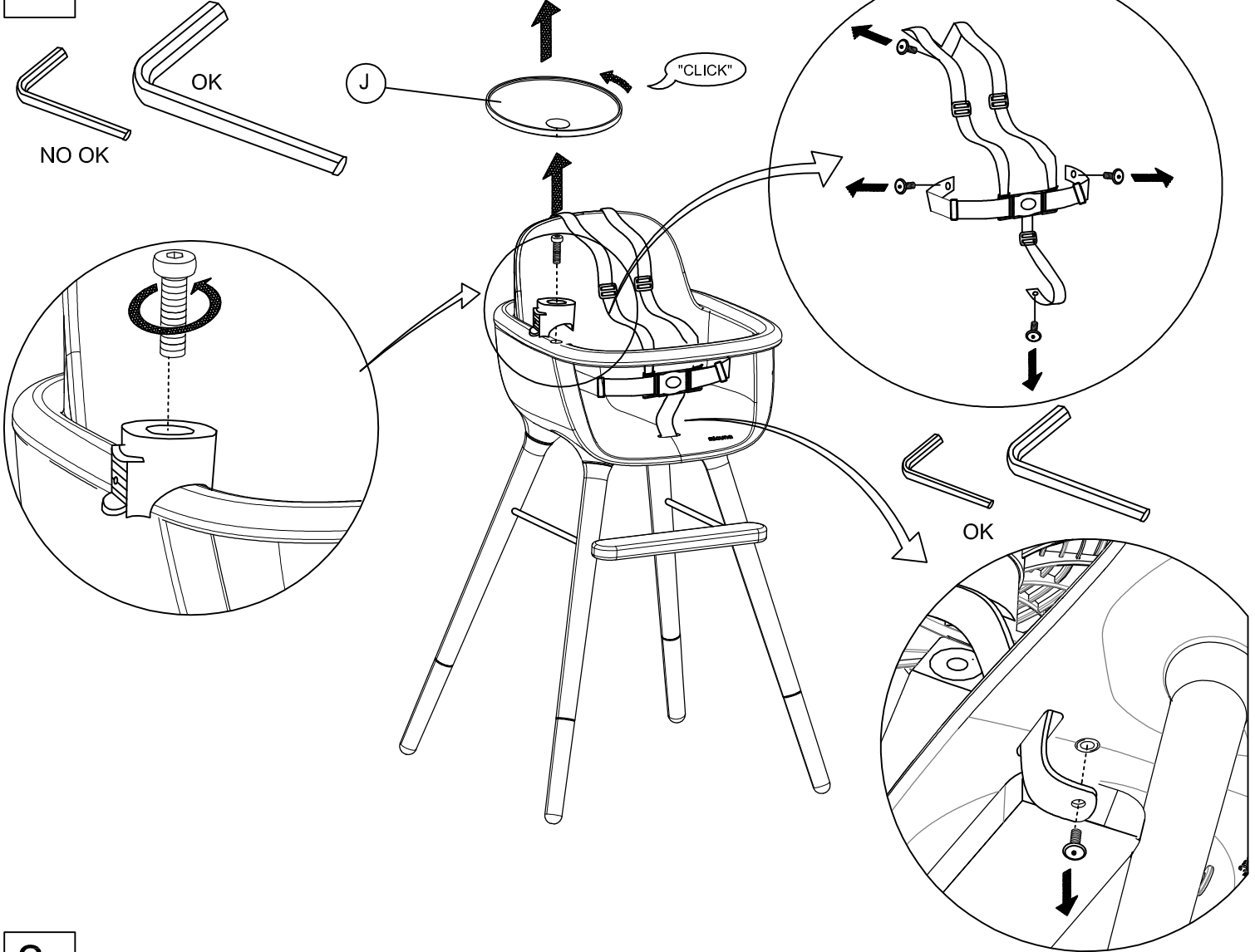

2.

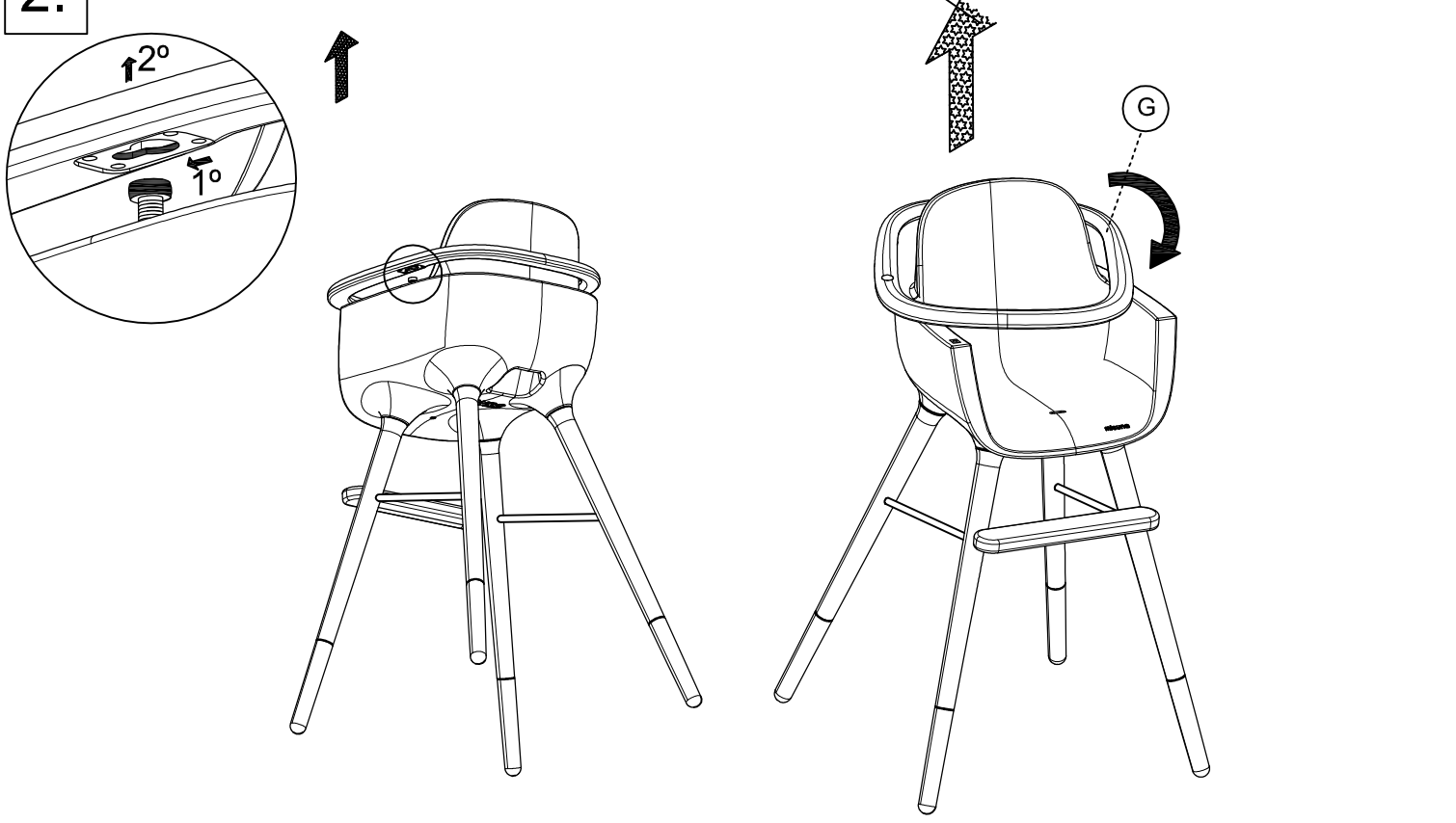

3.

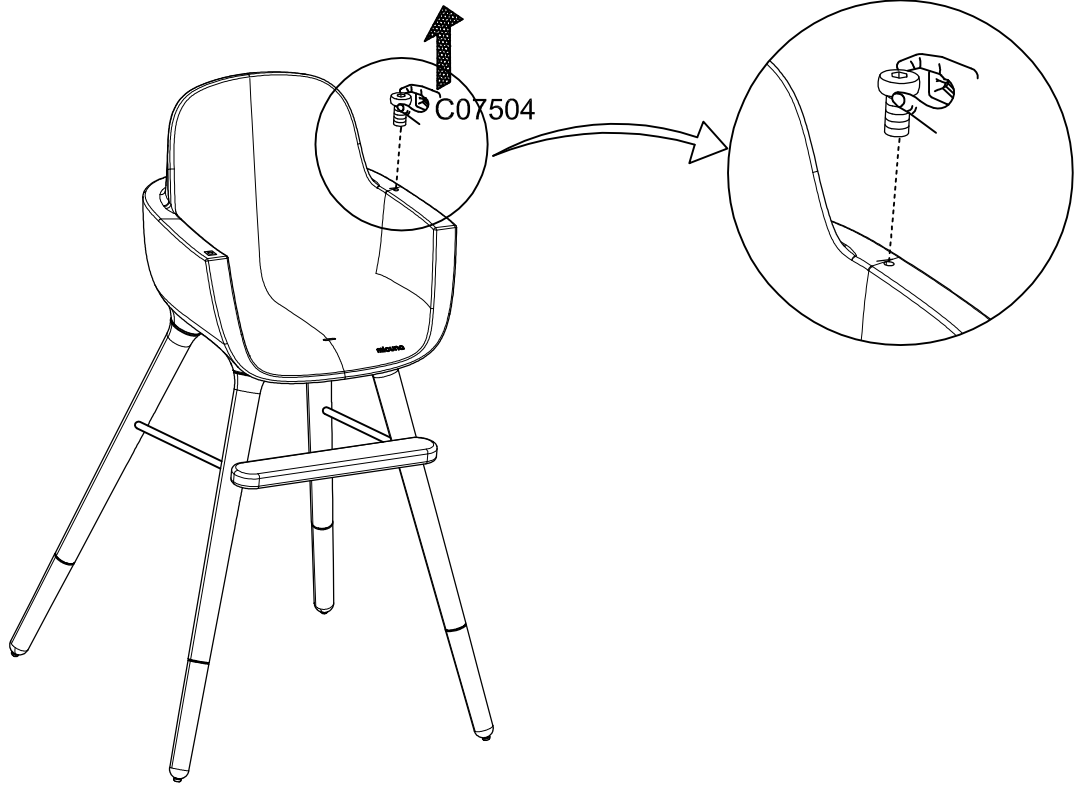

4.

OVO ORIGINAL ONE

4.

OVO ORIGINAL CITY

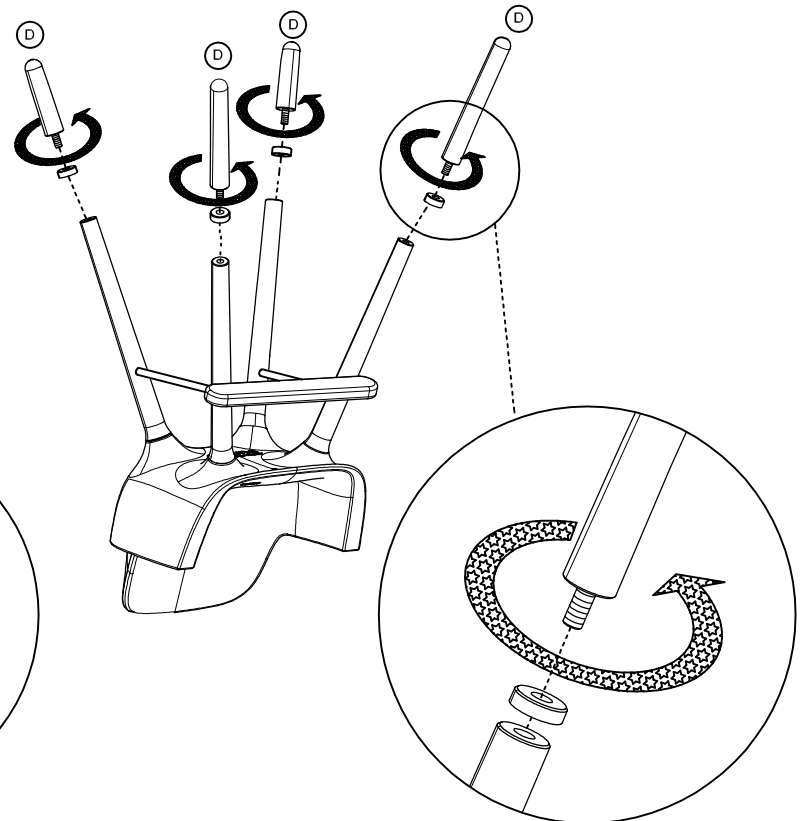
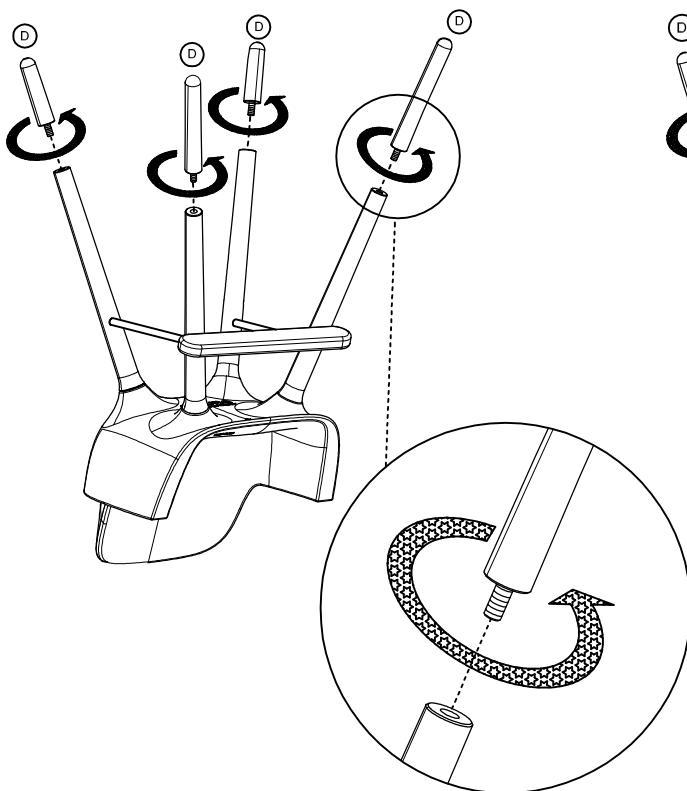
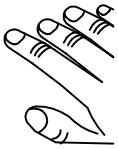

5023793

5.

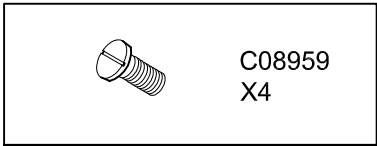
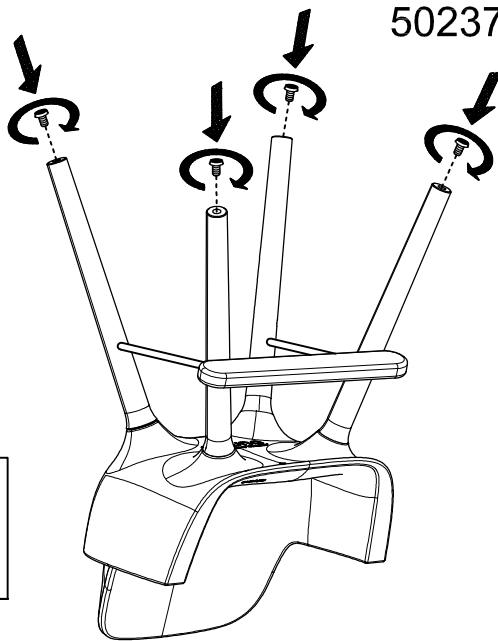

Opcion 1  
Option 1

6a.

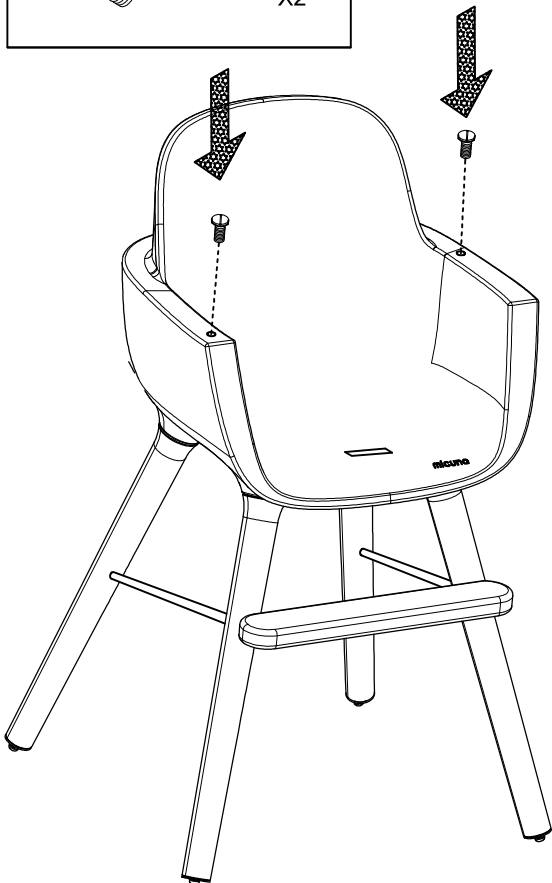
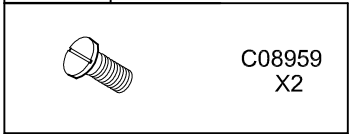

Opción 2  
Option 2.

Para la opción 2 repetir los pasos de la pagina 5  
For option 2 repeats the steps on page 5.

Opción 2  
Option 2.

6b.

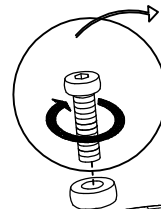
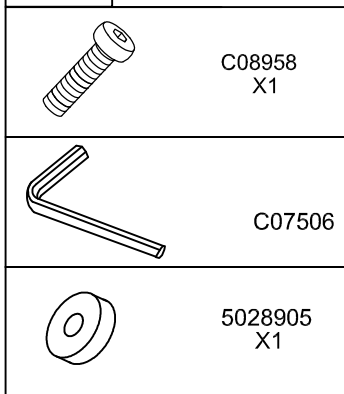

Usar tornillo pagina 6.  
Use metal bolt page 6.

